

**4K@60 and HDCP 2.2 supported HDMI Distribution Amplifier
(with Audio De-embedder)**

VAC-2000UHD / 4000UHD

<User's Guide>

Ver.1.3.0

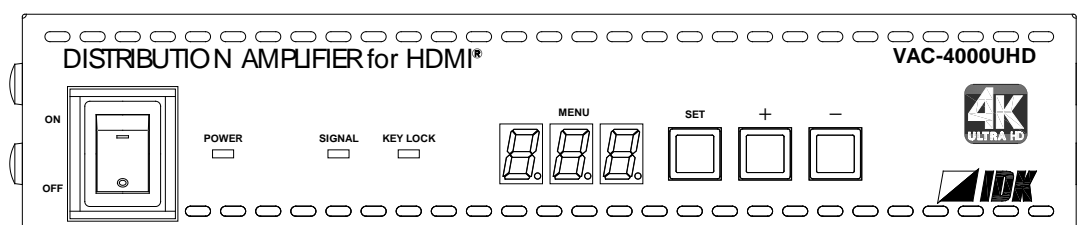
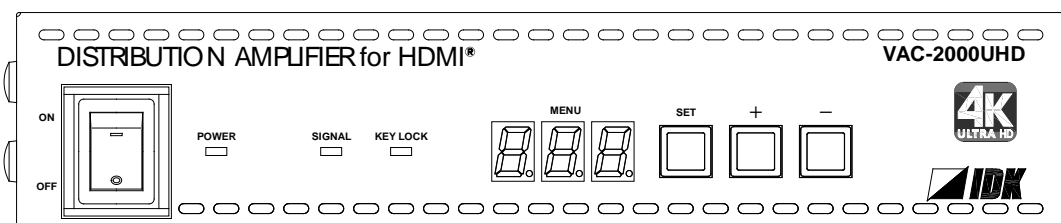

- Thank you for choosing this IDK product.
- To ensure the best performance of this product, please read this User's Guide fully and carefully before using it and keep this manual beside this product.

Trademarks

- Blu-ray Disc and Blu-ray is a trademarks of Blu-ray Disc Association.
- The terms HDMI and HDMI High-Definition Multimedia Interface, and the HDMI Logo are trademarks or registered trademarks of HDMI Licensing Administrator, Inc. in the United States and other countries.
- The terms Anti-snow and Connection Reset are registered trademarks of IDK Corporation in Japan.
- All other company and product names mentioned in this manual are either registered trademarks or trademarks of their respective owners. In this manual, the “®” or “™” marks may not be specified.

Before reading this manual

- All rights reserved.
- Some of the contents in this User's Guide such as appearance diagrams, menu operations, communication commands, and so on may differ depending on the version.
- This User's Guide is subject to change without notice. You can download the latest version from IDK's website at: <http://www.idk.co.jp/en/index.html>

FCC STATEMENT

This equipment has been tested and found to comply with the limits for a Class A digital device, pursuant to part 15 of the FCC Rules. These limits are designed to provide reasonable protection against harmful interference when the equipment is operated in a commercial environment. This equipment generates, uses, and can radiate radio frequency energy and, if not installed and used in accordance with the instruction manual, may cause harmful interference to radio communications. Operation of this equipment in a residential area is likely to cause harmful interference and the user will be required to correct that interference at their own expense.

CE MARKING

This equipment complies with the essential requirements of the relevant European health, safety and environmental protection legislation.

WEEE MARKING











Waste Electrical and Electronic Equipment (WEEE), Directive 2011/65/EU
(This directive is only valid in the EU.)







This equipment complies with the WEEE Directive (2011/65/EU) marking requirement.
The left marking indicates that you must not discard this electrical/electronic equipment in domestic household waste.





Safety instructions

Read and understand all safety and operating instructions before using this product. Follow all instructions and cautions as detailed in this document.

Enforcement Symbol	Description
 Warning	Indicates the presence of a hazard that may result in death or serious personal injury if the warning is ignored or the equipment is handled incorrectly.
 Caution	Indicates the presence of a hazard that may cause minor personal injury or property damage if the caution is ignored or the equipment is handled incorrectly.

Symbol	Description	Example
 Caution	This symbol is indicated to alert the user. (Warning and caution)	 Electrical Hazard
 Prohibition	This symbol is intended to prohibit the user from actions.	 Do not disassemble
 Instruction	This symbol is intended to instruct the user.	 Unplug

 Warning	
 Prohibition	Do not place the product in any unstable place. Install the product to a horizontal and stable place. Otherwise, it may fall/turn over and lead to injury.
	Do not place the product in any environment with vibration. Otherwise, it may move/fall and lead to injury.
	Keep out any foreign objects. In order to avoid fire or electric shock, do not allow foreign objects, such as metal and paper, to enter the product from the vent holes.
	For power cable/plug: <ul style="list-style-type: none"> • Do not scratch, heat, or modify, including extending them • Do not pull, put heavy stuff on them, or pinch them. • Do not bend, twist, or tie them together forcefully. If they are used in those states continuously, it may cause fire or electric shock. If power cables/plugs become damaged, contact IDK.
 Do not disassemble	Do not repair, modify or disassemble. Since the product includes high-voltage parts, those actions may cause fire or electric shock. For internal inspections or repairs, contact IDK.
 Do not touch	In the event of lighting or thunder, do not touch the main unit and cables such as power cable and LAN cable. Contact may cause electric shock
 Instruction	For installation: The product is intended to be installed by skilled technicians. For installation, please contact a system integrator or IDK. Otherwise, it may cause fire, electric shock, injury, or property damage.
	Set the power plug in a convenient place to unplug easily. You can easily unplug in case of any extraordinary failure or abnormal situation, and it also helps for unplugging when you do not use it for a long period.
	Plug the power plug into appropriate outlet completely. If the plug is plugged incompletely, it may overheat which causes electrical shock or fire. Do not use damaged plug or loosened outlet.
	Clean the power plug regularly. If the plug is covered in dust, it may cause fire due to reduced insulating power.
 Unplug	Unplug immediately if the product smokes, makes unusual noise, or smells. If you continue to use the product under those situations, it may cause electric shock or fire. After confirming that the product stops smoking, contact IDK.
	Unplug immediately if you drop the product or if the cabinet is damaged. If you continue to use the product under those situations, it may cause electrical shock or fire. For maintenance and repair, contact IDK.
	Unplug immediately if water or other objects are directed inside. If you continue to use it under those situations, it may cause electrical shock or fire. For maintenance and repair, contact IDK.
For connection	
 Instruction	Differences in ground potential among the product and peripheral devices may cause electric shock or damage of the devices. When using cables to connect devices, including connection of long-distance transmission, unplug the power cables of all related devices. After connecting signal/control cables of each device, plug in the power cables of each device.

 Caution	
 Prohibition	<p>Do not place the product in any place where it will be subjected to high temperatures. If the product is subjected to direct sunlight or high temperatures, it may cause fire.</p>
	<p>Do not place the product in humid, oil smoke, or dusty place. If the product is placed near humidifiers or dusty area, it may cause fire or electric shock.</p>
	<p>Do not block the vent holes. If ventilation slots are blocked, it may cause fire or failure due to internal heat.</p>
	<p>Do not put heavy items on the product. It may fall/turn over and lead to injury.</p>
	<p>Do not exceed ratings of outlet and wiring devices. If several plugs are put in an outlet, it may cause fire and electric shock.</p>
	<p>Use only the provided AC adapter and power cable. Do not use the provided AC adapter and power cable with other products. If non-compliant adapter or power cables is used, it may cause fire or electrical shock. Use the supplied AC power connection cable.</p>
 No wet hands	<p>Do not plug or unplug with wet hands. It may cause electrical shock.</p>
 Instruction	<p>Use and store the product within the specified temperature/humidity range. If the product is used outside the range continuously, it may cause fire or electric shock.</p>
	<p>Turn off devices when they are connected to another device. It may cause fire or electric shock.</p>
 Unplug	<p>Unplug the power plug if you do not use the product for a long period. In case of defect, it may cause fire.</p>
	<p>Unplug the power plug before cleaning. It may cause electric shock.</p>

For installation

For rack mount devices:

 Instruction	<p>Mount the product to the rack meeting EIA standards, and maintain spaces above and below for air cooling. For your safety, attach an L-shape bracket in addition to the mount bracket kit for the front panel to balance the weight.</p>
---	---

For devices with rubber feet:

 Instruction	<p>Never insert only the screws into the holes after removing the rubber feet. It may lead to damage when the screws contact electrical circuit or parts inside of the product. To put the rubber feet back on, use only provided rubber feet and screws.</p>
---	---

Altitude:

 Instruction	<p>Do not place the product at elevations of 2,000 meters (6562 feet) or higher above sea level. Failure to do so may shorten the life of the internal parts and result in malfunctions.</p>
---	--

Table of Contents

1	Included items.....	8
2	Product outline.....	9
3	Features.....	10
4	Part names and descriptions	11
4.1	Front panel.....	11
4.2	Rear panel.....	12
5	Sample application.....	13
6	Precautions before connection	14
7	Basic operation	15
7.1	Menu operations.....	15
7.2	Locking menu operation keys	16
7.3	Initialization	16
8	Menus.....	17
8.1	Menu list.....	17
8.2	Setting input and output (Setting menu).....	19
8.2.1	[F01 to F03] Copying EDID.....	19
8.2.2	[F10] Setting EDID resolution	20
8.2.3	[F12] Setting external EDID.....	23
8.2.4	[F14] Setting copied EDID	23
8.2.5	[F16] No-signal input monitoring.....	24
8.2.6	[F20] Setting Deep Color	25
8.2.7	[F22] Setting PCM Audio.....	25
8.2.8	[F24] Setting AC-3 Dolby Digital Audio	25
8.2.9	[F26] Setting AAC Audio.....	26
8.2.10	[F28] Setting Dolby Digital Plus Audio.....	26
8.2.11	[F30] Setting DTS Audio.....	26
8.2.12	[F32] Setting DTS-HD Audio.....	27
8.2.13	[F34] Setting Dolby TrueHD Audio.....	27
8.2.14	[F36] Setting Audio channel.....	28
8.2.15	[F38] Copying CEC physical address copy of EDID	29
8.2.16	[F42] Setting EDID WXGA.....	29
8.2.17	[F70 to F7n] Setting audio output.....	29
8.2.18	[F90] Displaying firmware version.....	30
8.2.19	[F99] Setting maintenance/status display menu	30
8.3	Checking operation (Maintenance menu).....	31
8.3.1	[C01] Setting HDCP input.....	31
8.3.2	[C10 to C1n] Setting how long Hot plug is ignored	32
8.3.3	[C20 to C2n] Setting forced HDMI output mode	33
8.3.4	[C30 to C3n] Setting output mode.....	34
8.4	Displaying input/output statuses (Status display menu).....	35
8.4.1	[L01 to L22] Displaying input information	35
8.4.2	[L30 to Lbn] Displaying output information	38
9	Specifications.....	40
9.1	Pin assignments.....	40
9.1.1	HDMI TypeA connector	40
9.2	Product specification.....	41
10	Troubleshooting	43

1 Included items

Make sure all items below are included in the package.
If any items are missing or damaged, please contact us.

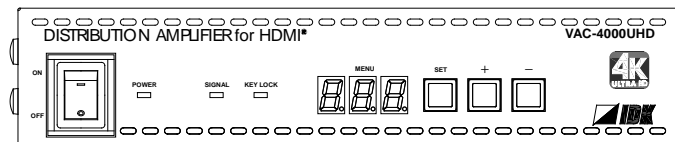

VAC main unit x 1
(Drawing: VAC-4000UHD)

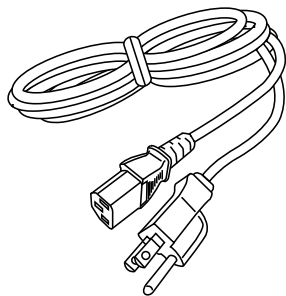

Power cable (1.8m/5.9 feet) x1

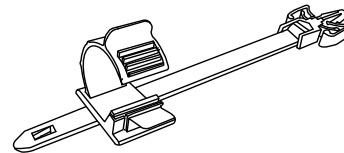

Cable clamps
VAC-2000UHD ... 3 clamps
VAC-4000UHD ... 5 clamps

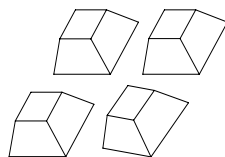

Rubber feet x 4

[Fig. 1.1] Included items

You can download the latest version of the User's Guide from IDK's website at:
<http://www.idk.co.jp/en/index.html>

2 Product outline

The VAC-2000UHD and VAC-4000UHD are HDMI distribution which supports 4K@60 having four times the resolution of full HD. These distributors include 1 HDMI connector for input, 2 (VAC-2000UHD) or 4 (VAC-4000UHD) HDMI connectors for output, and an analog audio output connector.

Input video signals are output from HDMI output connectors while digital audio signals are converted into analog audio signals and output from the audio output connector.

The VAC-2000UHD and VAC-4000UHD supports HDCP 2.2 for HDMI signals.

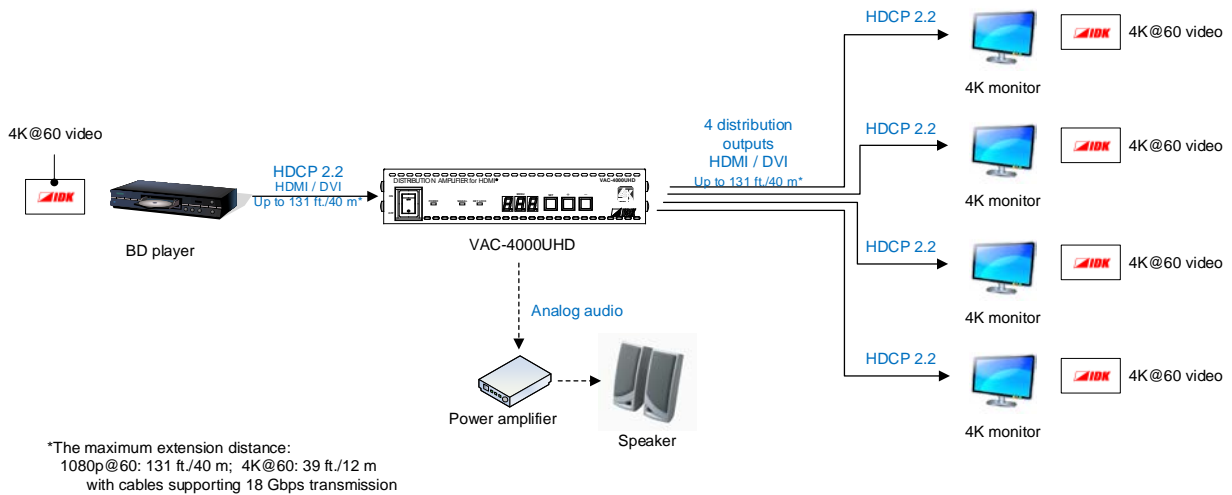

[Fig. 2.1] Distributing video and audio (VAC-4000UHD)

3 Features

■ Video

- 1 HDMI input; 2 / 4 outputs (VAC-2000UHD / VAC-4000UHD)
- Up to 4K@60 (4:4:4) resolution
- HDCP 1.4 / 2.2
- HDR
- 3D
- xvYCC
- Maximum input/output cable distance:
 - 1080p@60: up to 131 ft. (40 m)
 - 4K@60: up to 39 ft. (12 m) (using 18 Gbps supported High-Speed HDMI cable)
- Cascade connection
- Anti-snow

■ Audio

- Analog audio de-embedded

■ Others

- EDID emulation
- DDC buffering
- CEC: Pass-Through between IN and OUT1
- Displaying statuses of Input/Output signals
- Connection Reset

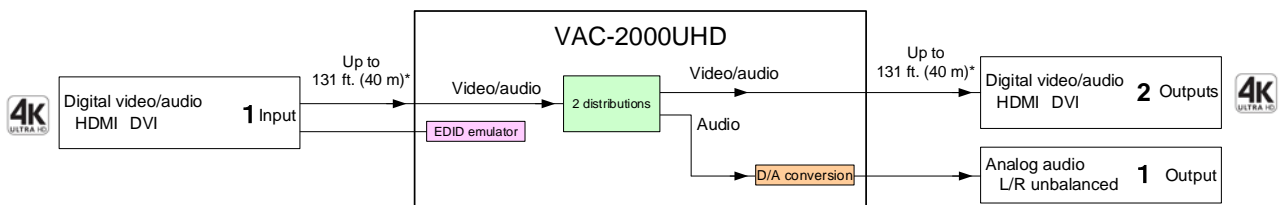

* The maximum extension distance:
 1080p@60: 131 ft. (40 m); 4K@60: 39 ft. (12 m) (with cables supporting 18 Gbps transmission)

[Fig. 3.1] VAC-2000UHD diagram

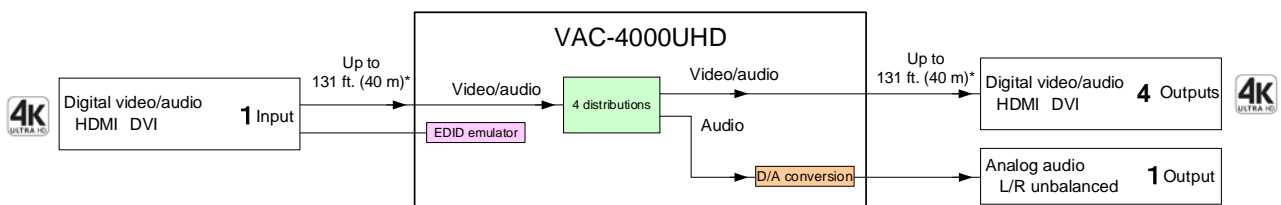

* The maximum extension distance:
 1080p@60: 131 ft. (40 m); 4K@60: 39 ft. (12 m) (with cables supporting 18 Gbps transmission)

[Fig. 3.2] VAC-4000UHD diagram

4 Part names and descriptions

4.1 Front panel

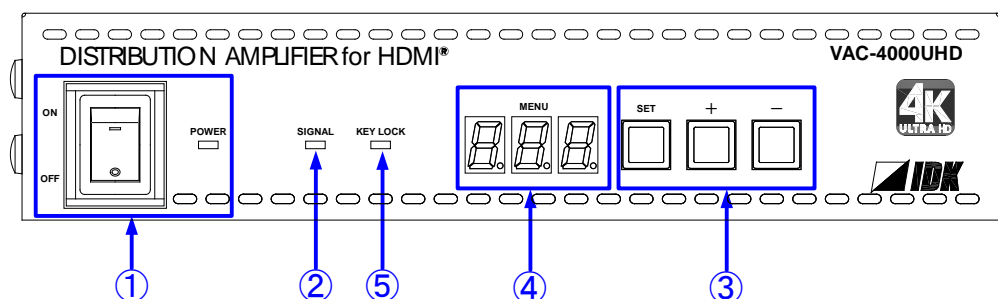

[Fig. 4.1] Panel drawing (VAC-4000UHD)

[Table 4.1] Part names and descriptions

#	Part name	Description
①	POWER key	Turns on/off the VAC. The POWER LED lights green when the VAC is turned on.
②	SIGNAL LED	The LED lights yellow when video input signals are detected.
③	Menu operation keys	Selects and sets each menu.
④	Segment display	Displays menu number, setting number, and setting status.
⑤	KEY LOCK LED	Turns green when the menu operation keys are locked. 【7.2 Locking menu operation keys】

4.2 Rear panel

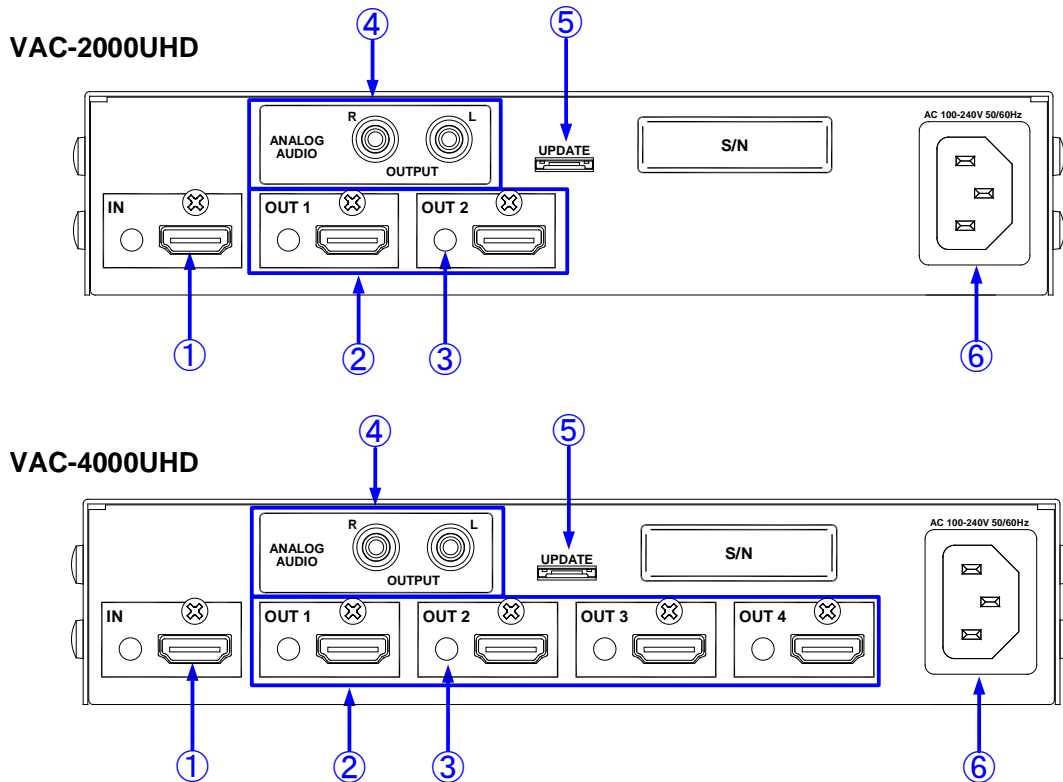

[Fig. 4.2] Panel drawing

[Table 4.2] Part names and descriptions

#	Part name	Description
①	HDMI input connector	Input connector for HDMI signals. Connector for a source device such as a DVD/Blu-ray disc player.
②	HDMI output connector	Output connector for HDMI signals. Connector for sink devices such as LCD monitors and projectors.
③	HDMI cable fixing hole	Holes for the supplied cable clamps to fix the HDMI cables. 【6 Precautions before connection】
④	Audio output connector	Analog output for audio of HDMI input signals. Connector for an amplifier, speaker, mixer, or the like.
⑤	Connector for maintenance	Not used. Please do not connect anything; this connector is for maintenance only.
⑥	AC adapter connector	Connector for the supplied AC adapter.

5 Sample application

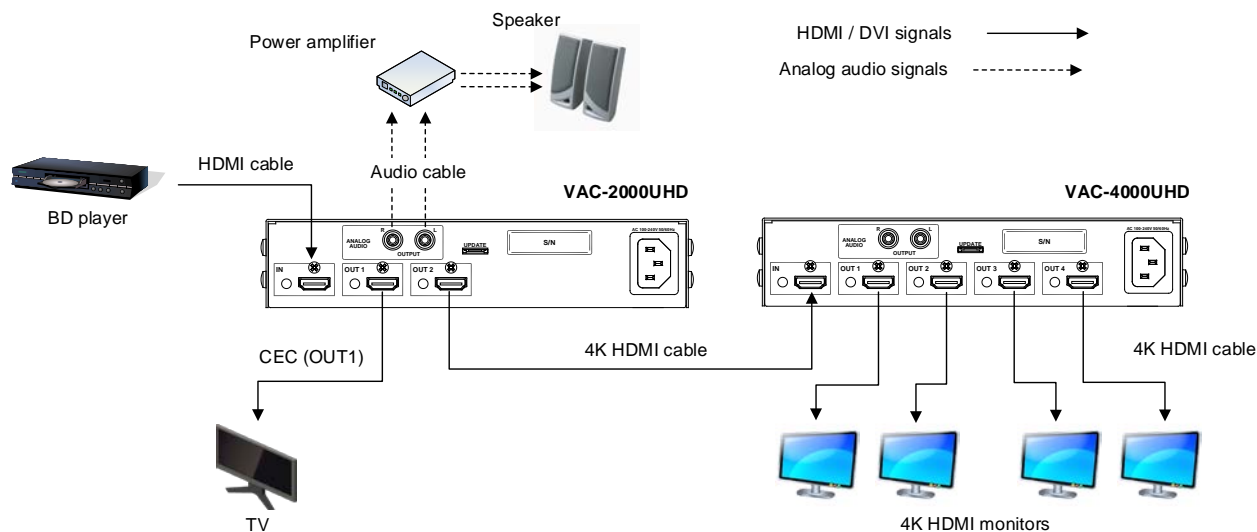

[Fig. 5.1] Cascade connection

At IDK, various cables, such as flexible HDMI cable, DVI cable, high-quality long cables and conversion cables, are available. Please contact us for details as needed.

Use correct HDMI cable /HDMI-DVI conversion cable according to the system configuration. For analog audio, use a commercial audio cable.

For 4K format video, the maximum TMDS data rate (transmission rate) is 18 Gbps. If you use a high-speed HDMI cable, the rate becomes 10.2 Gbps and video cannot be displayed stably.

Use a cable supporting 18 Gbps high-speed transmission according to the 4K format. Since extension distance depends on the cable type and characteristics of source and sink devices, we recommend that you use a high-quality cable.

[Table 5.1] Cables for 4K format

	TMDS data rate (Gbps)								
	RGB, YCbCr 4:4:4			YCbCr 4:2:2			YCbCr 4:2:0		
4K format	24 bit	30 bit	36 bit	24 bit	30 bit	36 bit	24 bit	30 bit	36 bit
3840x2160p (24 / 25 / 30)	HS	UH	UH	HS	HS	HS	NA	NA	NA
4096x2160 (24 / 25 / 30)	HS	UH	UH	HS	HS	HS	NA	NA	NA
3840x2160p (50 / 59.94 / 60)	UH	NA	NA	UH	UH	UH	HS	UH	UH
4096x2160 (50 / 59.94 / 60)	UH	NA	NA	UH	UH	UH	HS	UH	UH

UH: 18 Gbps ultra-high-speed cable HS: 10.2 Gbps transmission cable NA: Not available

Note:

If cables are extended using a cable joint (JJ), video may be interrupted or not be output.

6 Precautions before connection

Follow the precautions below before connecting to external devices.

■ Attaching rubber feet

1. Turn the VAC upside down and place it on a flat place.
2. Wipe the dirt off joint area.
3. Peel the release papers from rubber feet and place them on each corner of the VAC.

■ Installation

- Eliminate static electricity from your body before connecting cables.
- Do not place another VAC on the VAC.
- Do not block vent holes. Keep enough space (1.2 in. (30 mm) or more) around the product.
- Do not install the VAC in a closed space.

If you have to install the product to an EIA rack mount in closed space, add a ventilation to keep the ambient temperature of 40 degrees C/104 degrees F or less. If inadequately vented, the life of parts may be shortened and operations may be affected.

■ Cabling

- Read the manuals of external devices carefully
- Turn off the transmitter/receiver before connection.
- Insert the cable into the connector firmly and do not give the connector stress.
- Secure the HDMI cable using a cable clamp to prevent it from falling out of the device.

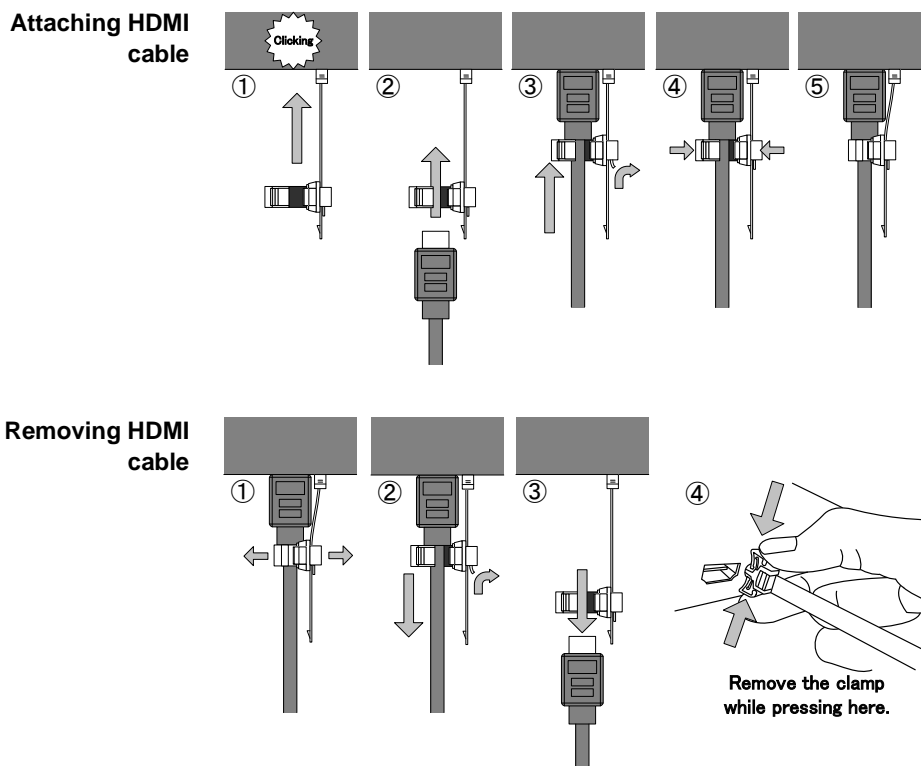

[Fig. 6.1] Attaching/Removing cable clamp

7 Basic operation

7.1 Menu operations

You can set all input/output settings of video and audio signals from menu operation keys.

Menu operation keys

Select the menu number first and then select the setting number.

If you do not operate for 60 seconds in each step, the light of the segment display will be turned off.

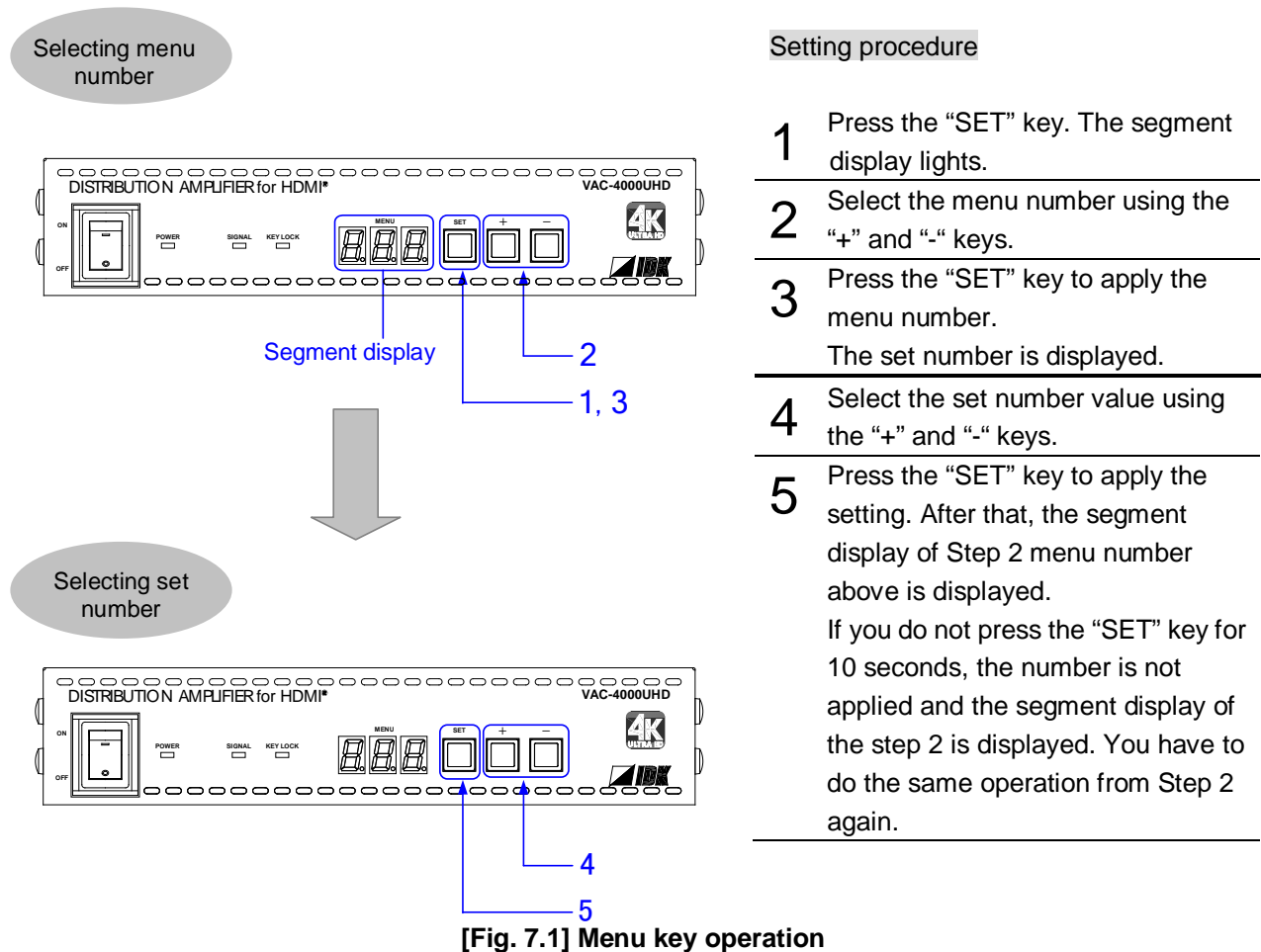

7.2 Locking menu operation keys

Press and hold the "SET" key for 3 seconds or longer to set/cancel key lock.

If the VAC is powered off with keys locked, the key are still locked at the time of reboot

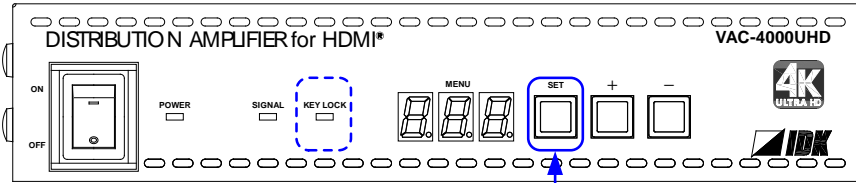

Menu operation keys will be locked by pressing the "SET" key for three seconds.



[Fig. 7.2] Locking menu operation keys

7.3 Initialization

All input and output settings will be initialized by powering on while pressing the "SET" key.

Note:

Once settings are initialized, they cannot be restored to the previous settings.

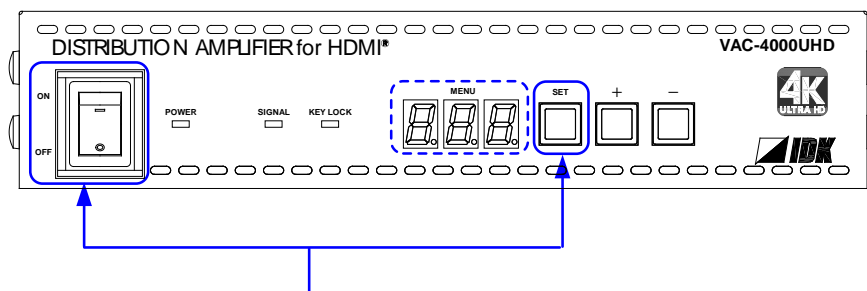

All input and output settings will be initialized by powering on while pressing the "SET" key.



[Fig. 7.3] Initialization

8 Menus

- Setup menus: setting video and audio signals in normal use
- Maintenance menus: checking operation
- Status display menus: displaying statuses of input signals and connection with sink devices

Note:

Normally, the maintenance menu and status display menu are not displayed as a default.
To display them, use the setting menu number [F99].

【8.2.19 [F99] Setting maintenance/status display menu】

8.1 Menu list

■ Setup menu

[Table 8.1] Setup menus

Menu number	Function	Setting	
		Set value	Default
F01 to F03	Copying EDID	OUT1 to OUT2 / OUT4 ^{*1}	OUT1
F10	Setting EDID resolution (default)	SVGA to UHDTV	1080p
F12	Setting external EDID	OUT1 to OUT2 / OUT4 ^{*1}	OUT1
F14	[F14] Setting copied EDID	Copy data 1 to 3	Copy data 1
F16	[F16] No-signal input monitoring	OFF / 2 to 15 [sec.]	10 [sec.]
F20	Setting Deep Color	24 / 30 / 36 [bit]	24 [bit]
F22	Setting PCM Audio	32 / 44.1 / 48 / 88.2 / 96 / 192 [kHz]	48 [kHz]
F24	Setting AC-3 Dolby Digital Audio	OFF / ON	OFF
F26	Setting AAC Audio	OFF / ON	OFF
F28	Setting Dolby Digital Plus Audio	OFF / ON	OFF
F30	Setting DTS Audio	OFF / ON	OFF
F32	Setting DTS-HD Audio	OFF / ON	OFF
F34	Setting Dolby TrueHD Audio	OFF / ON	OFF
F36	Setting Audio channel	2 channels / 3 (2.1) channels / 6 (5.1) channels / 8 (7.1) channels	2 channels

^{*1} VAC-2000UHD:OUT2, VAC-4000UHD:OUT4

Menu number	Function	Setting	
		Set value	Default
F38	Copying CEC physical address copy of EDID	Copy/No copy	No copy
F42	Setting EDID WXGA	1366 × 768 / 1360 × 768	1360 × 768
F70 to F7n ^{*2}	Setting audio output	ON / OFF	ON
F90	Displaying firmware version	—	—
F99	Setting maintenance/status display menu	No display/Display/Always display	No display

^{*2}VAC-2000UHD: n=1, VAC-4000UHD: n=3

■ Maintenance menu

[Table 8.2] Maintenance menus

Menu number	Function	Setting	
		Set value	Default
C01	Setting HDCP input	Enable HDCP 2.2 encryption/ Enable HDCP 1.4 encryption/ Disable HDCP encryption	Enable HDCP 2.2 encryption
C10 to C1n [*]	Setting how long Hot plug is ignored	OFF/2 to15 [sec.]	OFF
C20 to C2n [*]	Setting forced HDMI output mod	oFF: DVI when reading EDID error. Er1: HDMI (without SCDC) when reading EDID error. AL1: Always HDMI (without SCDC). Er2: HDMI (with SCDC) when reading EDID error. AL2: Always HDMI (with SCDC).	DVI when reading EDID error.
C30 to C3n [*]	Setting output mode	Automatic / DVI / RGB / YCbCr 4:2:0 / YCbCr 4:2:2 / YCbCr 4:4:4	Automatic

*VAC-2000UHD: n=1, VAC-4000UHD: n=3

■ Status display menu

[Table 8.3] Status display menus

Menu number	Function	Setting	
		Set value	Default
L01 to L22	[L01 to L22] Displaying input information	—	—
L30 to Lbn [*]	Displaying output information	—	—

*VAC-2000UHD: n=1, VAC-4000UHD: n=3

8.2 Setting input and output (Setting menu)

8.2.1 [F01 to F03] Copying EDID

Note:

“[]” shows each menu number in this chapter.

EDID of sink devices can be read and stored, and the copied EDID can apply in the same way of internal EDID.

Registering EDID:

1. Save the sink device EDID to a Copy Data (1 to 3): Menu number [F01 to F03]
2. Select the copy data you want to use: Menu number [F14]
3. Select the Copy EDID: Menu number [F10]

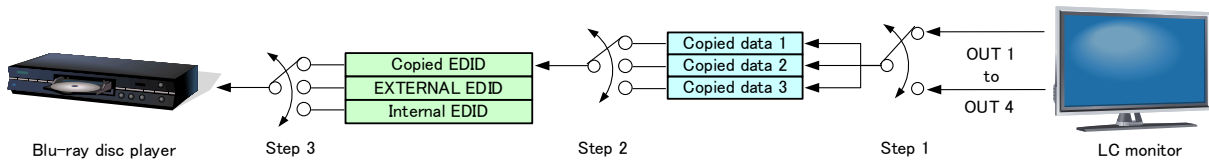

[Fig. 8.1] Copying EDID (VAC-4000UHD)

Menu numbers

F01 to F03: Copied data 1 to 3

Setting values

- 01 to 02:OUT1 to OUT2 (VAC-2000UHD) [Default] OUT1
- 01 to 04:OUT1 to OUT4 (VAC-4000UHD) [Default] OUT1

Note:

If cascade connection is employed, the source device will read the EDID of the source-device-side VAC. If two or more distributors are connected between a sink device and source device, follow the procedure below to read EDID data.

1. Copy the EDID of the sink device into the sink-device-side VAC and set it as “Copied EDID” or “EXTERNAL (External EDID)”.
2. Copy the EDID of the sink-device-side VAC into the source-device-side VAC and set it as “Copied EDID” or “EXTERNAL (External EDID)”.

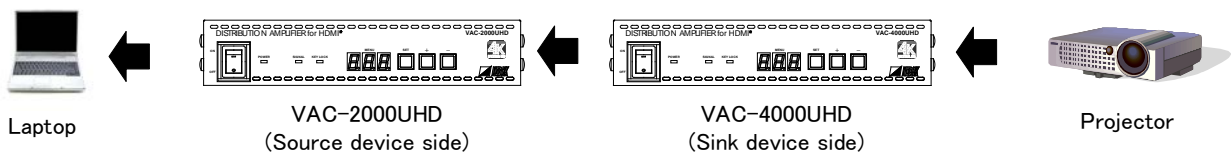

[Fig. 8.2] Reading EDID in cascade connection

8.2.2 [F10] Setting EDID resolution

You can set the EDID to be sent to the source device:

In order to use a built-in EDID (setting values "03" to "28"), set the maximum resolution supported by the sink device using setting values "03" to "28".

Setting values

[Table 8.4] The maximum resolution of EDID

Setting values	Maximum resolution	Pixel	Standard	Remarks	
01	EXTERNAL (External EDID)	—	—	If no sink device is connected, the previous setting will be applied.	
02	Copy EDID	—	—	If no collected data, its default is 03.	
03	1080p(59.94 / 60)	1920 × 1080	HDTV	Default	
04	720p	1280 × 720			
05	1080i	1920 × 1080			
06	1080p (24 / 25 / 30 / 50)	1920 × 1080			
07	SVGA	800 × 600		VESA	
08	XGA	1024 × 768			
09	VESA720	1280 × 720	For DVI device input		
10	WXGA	1280 × 768			
11	WXGA	1280 × 800			
12	Quad-VGA	1280 × 960			
13	SXGA	1280 × 1024			
14	WXGA	1360 × 768、 1366 × 768	The number of pixels can be set in "8.2.16 Selecting EDID WXGA".		
15	SXGA+	1400 × 1050			
16	WXGA+	1440 × 900			
17	WXGA++	1600 × 900	(RB)		
18	UXGA	1600 × 1200			
19	WSXGA	1680 × 1050			
20	VESA1080	1920 × 1080	(RB), For DVI device input		
21	WUXGA	1920 × 1200	(RB)		
22	QWXGA	2048 × 1152	(RB)		
23	WQHD	2560 × 1440	(RB)		
24	WQXGA	2560 × 1600	(RB)		

(RB) : Reduced Blanking

[Table 8.5] The maximum resolution of EDID

Setting values	Maximum resolution	Pixel	Standard	Remarks
41	2160p (24 / 25 / 30)	3840 × 2160	UHDTV	
42	4096x2160 (24 / 25 / 30)	4096 × 2160	DCI	
43	2160p (50 / 59.94 / 60, 4:2:0)	3840 × 2160	UHDTV	YCbCr 4:2:0 supported
44	4096x2160 (50 / 59.94 / 60, 4:2:0)	4096 × 2160	DCI	YCbCr 4:2:0 supported
45	2160p (50 / 59.94 / 60, 4:4:4)	3840 × 2160	UHDTV	YCbCr 4:2:0, YCbCr 4:2:2, YCbCr 4:4:4 supported
46	4096x2160 (50 / 59.94 / 60, 4:4:4)	4096 × 2160	DCI	YCbCr 4:2:0, YCbCr 4:2:2, YCbCr 4:4:4 supported

Notes:

- For 4096x2160 (Setting values, 42, 44, and 46)
The source device may first select 3840x2160 (30p, YCbCr 4:4:4) depending on the EDID definition. Set the built-in EDID first and then select a resolution of 4096x2160 for the source device.
- For YCbCr4:2:0 (Setting values, 43 and 44)
The source device may first select 3840x2160 (30p, YCbCr 4:4:4) depending on the EDID definition. Set the built-in EDID first and then select a Color depth of YCbCr 4:2:0 for the source device.

[8.2.3 [F12] Setting external EDID]

[8.2.4 [F14] Setting copied EDID]

[8.2.16 [F42] Setting EDID WXGA]

[Table 8.6] The maximum resolution and EDID supported pixels

Max. resolution (Setting values)	EDID supported Pixels																								
	640 × 480	800 × 600	1024 × 768	1280 × 720	1280 × 768	1280 × 800	1280 × 960	1280 × 1024	1360 × 768*	1366 × 768*	1400 × 1050	1440 × 900	1600 × 900	1600 × 1200	1680 × 1050	1920 × 1080	1920 × 1200	2048 × 1152	2560 × 1440	2560 × 1600	3840 × 2160 (30p)	4096 × 2160 (30p)	3840 × 2160 (60p)	4096 × 2160 (60p)	
01	—	—	—	—	—	—	—	—	—	—	—	—	—	—	—	—	—	—	—	—	—	—	—	—	—
02	—	—	—	—	—	—	—	—	—	—	—	—	—	—	—	—	—	—	—	—	—	—	—	—	—
03	1080p (59.94 / 60)	○	○	○	×	×	○	○	○	○	○	○	○	○	○	○	○	×	×	×	×	×	×	×	×
04	720p	○	○	×	○	×	×	×	×	×	×	×	×	×	×	×	×	×	×	×	×	×	×	×	×
05	1080i	○	○	○	×	×	×	×	×	×	×	×	×	×	×	×	×	×	×	×	×	×	×	×	×
06	1080p (24 / 25 / 30 / 50)	○	○	○	×	×	○	○	○	○	○	○	○	○	○	○	○	×	×	×	×	×	×	×	×
07	800x600	○	○	×	×	×	×	×	×	×	×	×	×	×	×	×	×	×	×	×	×	×	×	×	×
08	1024x768	○	○	○	×	×	×	×	×	×	×	×	×	×	×	×	×	×	×	×	×	×	×	×	×
09	1280x720	○	○	○	○	×	×	×	×	×	×	×	×	×	×	×	×	×	×	×	×	×	×	×	×
10	1280x768	○	○	○	○	○	×	×	×	×	×	×	×	×	×	×	×	×	×	×	×	×	×	×	×
11	1280x800	○	○	○	○	○	×	×	×	×	×	×	×	×	×	×	×	×	×	×	×	×	×	×	×
12	1280x960	○	○	○	○	○	○	×	×	×	×	×	×	×	×	×	×	×	×	×	×	×	×	×	×
13	1280x1024	○	○	○	○	○	○	○	×	×	×	×	×	×	×	×	×	×	×	×	×	×	×	×	×
14	1360x768	○	○	○	○	○	○	○	○	○	×	×	×	×	×	×	×	×	×	×	×	×	×	×	×
15	1400x1050	○	○	○	○	×	○	○	○	○	○	×	×	×	×	×	×	×	×	×	×	×	×	×	×
16	1440x900	○	○	○	○	×	○	○	○	○	○	○	×	×	×	×	×	×	×	×	×	×	×	×	×
17	1600x900	○	○	○	○	×	○	○	○	○	○	○	○	×	×	×	×	×	×	×	×	×	×	×	×

8.2.3 [F12] Setting external EDID

You can set the HDMI output connector that will be read if EDID type is set to “EXTERNAL (External EDID)” in “8.2.2 [F10] Setting EDID resolution”.

1. Select the HDMI output connector: Menu numbers:[F12]
2. Select “EXTERNAL (External EDID)”: Menu numbers:[F10] (P.20)

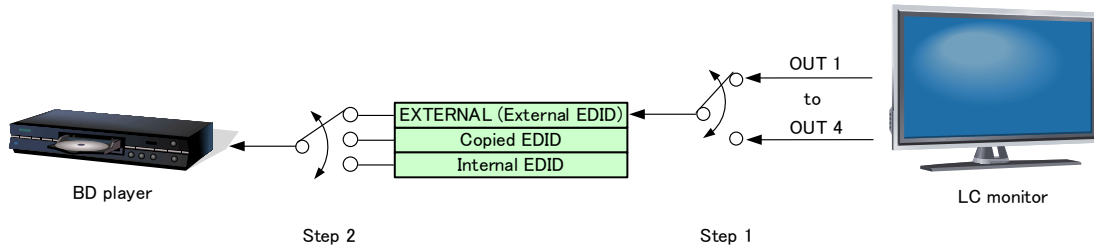

[Fig. 8.3] Registering external EDID (VAC-4000UHD)

Setting values

- 01 to 02:OUT1 to OUT2 (VAC-2000UHD) [Default] OUT1
- 01 to 04:OUT1 to OUT4 (VAC-4000UHD) [Default] OUT1

Notes:

- Set this menu before setting the EDID resolution to “01 EXTERNAL (External EDID)” in “8.2.2 [F10] Setting EDID resolution”.
- Set the external EDID again if
 - replacing the sink device with the VAC powered on or
 - changing the setting of the sink device with the VAC powered on.

8.2.4 [F14] Setting copied EDID

You can select the copied EDID data.

EDID copied (in 8.2.1 [F01 to F03] Copying EDID) from sink devices are saved in three areas.

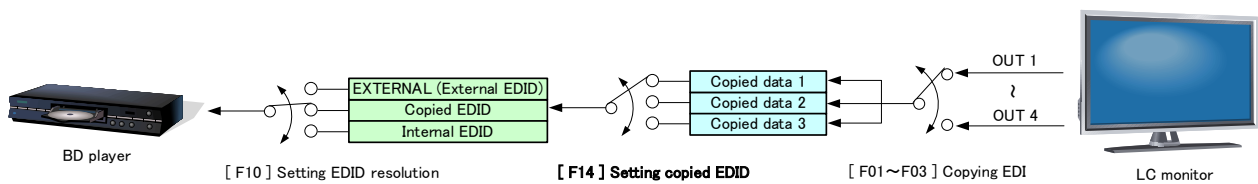

[Fig. 8.4] Setting copied EDID (VAC-4000UHD)

Setting values

- 01 to 03: Copied data 1 to 3 [Default] Copied data 1

Note:

Set this menu before setting the EDID resolution to “02 Copied EDID” in “8.2.2 [F10] Setting EDID resolution”.

8.2.5 [F16] No-signal input monitoring

If you change EDID of the VAC or turn on/off the VAC, the source devices may not output video signals. In this menu, you can set the monitoring time.

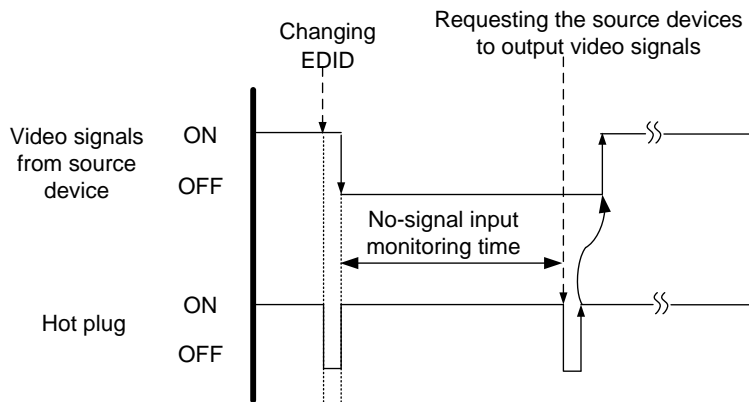

[Fig. 8.5] No-signal input monitoring time

Setting values

oFF: OFF

02 to 15: 2 to 15 seconds [Default]: 10 seconds

Notes:

- If you use the power saving or Dual monitor function of the PC (Source device), set this menu to "OFF". The PC that receives output request may cancel those functions.
- If you set the time that is shorter than the output timing, the source device repeats reprocessing of output video signals. In this case, change the time to longer.

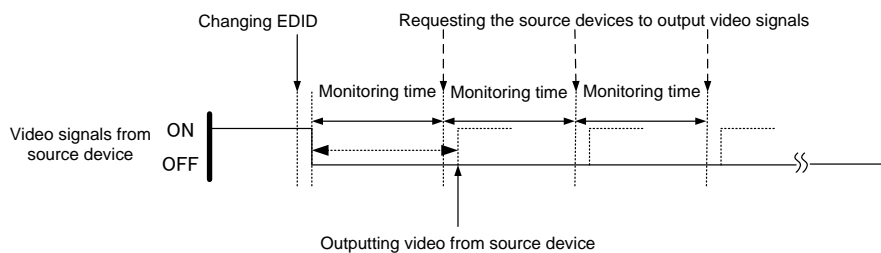

[Fig. 8.6] Repeating output signal setting

8.2.6 [F20] Setting Deep Color

You can set the Deep Color (color depth) that is output from the source device.

The setting will be applied only if one of 03 to 46 is selected for "8.2.2 [F10] Setting EDID resolution".

Setting values

08: 24 bit / pixel (8 bit / component) [Default]

10: 30 bit / pixel (10 bit / component)

12: 36 bit / pixel (12 bit / component)

Notes:

- If you select "30bit/pixel (10bit/component)" or "36bit/pixel (12bit/component)", the transmission clock will be faster resulting in noise on video when a poor-quality cable or long cable is connected. In this case, change the setting to "24bit/pixel (8bit/component)".
For the resolution of 4K@50 / 59.94 / 60 (YCbCr 4:4:4), the deep color will be 8 bit regardless of the setting of this menu.

8.2.7 [F22] Setting PCM Audio

You can set the maximum sampling frequency of PCM Audio that is output from the source device.

The setting will be applied only if one of 03 to 46 is selected for "8.2.2 [F10] Setting EDID resolution".

Setting values

32 : 32 kHz

44 : 44.1 kHz

48 : 48 kHz

88 : 88.2 kHz

96 : 96 kHz

192 : 192 kHz

Note:

Some LCD monitors do not support several audio formats. Select the audio format and sampling frequency supported by your devices.

8.2.8 [F24] Setting AC-3 Dolby Digital Audio

You can set the maximum sampling frequency of AC-3 Dolby Digital Audio that is output from the source device.

The setting will be applied only if one of 03 to 46 is selected for "8.2.2 [F10] Setting EDID resolution".

Setting values

on : ON (The maximum sampling frequency: 48 kHz)

oFF : OFF [Default]

Note:

Some LCD monitors do not support several audio formats. Select the audio format supported by your devices.

8.2.9 [F26] Setting AAC Audio

You can set the AAC Audio that is output from the source device.

The setting will be applied only if one of 03 to 46 is selected for "8.2.2 [F10] Setting EDID resolution".

Setting values

on : ON (The maximum sampling frequency: 96 kHz)

oFF : OFF [Default]

Note:

Some LCD monitors do not support several audio formats. Select the audio format supported by your devices.

8.2.10 [F28] Setting Dolby Digital Plus Audio

You can set the Dolby Digital Plus Audio that is output from the source device.

The setting will be applied only if one of 03 to 46 is selected for "8.2.2 [F10] Setting EDID resolution".

Setting values

on : ON (The maximum sampling frequency: 48 kHz)

oFF : OFF [Default]

Note:

Some LCD monitors do not support several audio formats. Select the audio format supported by your devices.

8.2.11 [F30] Setting DTS Audio

You can set the DTS Audio that is output from the source device.

The setting will be applied only if one of 03 to 46 is selected for "8.2.2 [F10] Setting EDID resolution".

Setting values

on : ON (The maximum sampling frequency: 96 kHz)

oFF : OFF [Default]

Note:

Some LCD monitors do not support several audio formats. Select the audio format supported by your devices.

8.2.12 [F32] Setting DTS-HD Audio

You can set the DTS-HD Audio that is output from the source device.

The setting will be applied only if one of 03 to 46 is selected for "8.2.2 [F10] Setting EDID resolution".

Setting values

- on : ON (The maximum sampling frequency: 192 kHz)
- oFF : OFF [Default]

Note:

Some LCD monitors do not support several audio formats. Select the audio format supported by your devices.

8.2.13 [F34] Setting Dolby TrueHD Audio

You can set the Dolby TrueHD Audio that is output from the source device.

The setting will be applied only if one of 03 to 46 is selected for "8.2.2 [F10] Setting EDID resolution".

Setting values

- on : ON (The maximum sampling frequency: 192 kHz)
- oFF : OFF [Default]

Note:

Some LCD monitors do not support several audio formats. Select the audio format supported by your devices.

8.2.14 [F36] Setting Audio channel

You can set the number of channels for the multiple-channel audio that is output from the source device. The setting will be applied only if one of 03 to 46 is selected for "8.2.2 [F10] Setting EDID resolution".

Setting values

- 02 : 2 channels [Default]
- 03 : 3 channels (2.1 channels)
- 06 : 6 channels (5.1 channels)
- 08 : 8 channels (7.1 channels)

■ The number of channels and speaker configuration

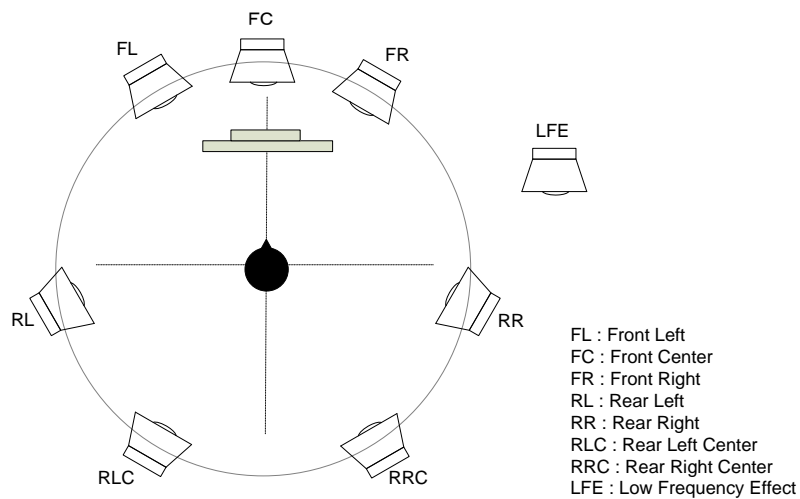

Speakers	FL / FR	LFE	FC	RL / RR	RLC / RRC
2 (2 channels)	ON	OFF	OFF	OFF	OFF
3 (2.1 channels)	ON	ON	OFF	OFF	OFF
6 (5.1 channels)	ON	ON	ON	ON	OFF
8 (7.1 channels)	ON	ON	ON	ON	ON

[Table 8.7] The number of channels and speaker configuration

8.2.15 [F38] Copying CEC physical address copy of EDID

CEC: Pass through between IN and OUT1

The CEC physical address of the sink device that is connected to OUT1 can be copied into the EDID of the VAC.

If the CEC physical address of the connected sink device and the VAC's address are not the same, the CEC functions, such as input switching in the sink device at start-up, may not work correctly. The problem can be solved by using the CEC physical address that is copied into the VAC.

The setting will be applied only if CEC-supported source and sink devices are connected and one of 03 to 46 is selected for "8.2.2 [F10] Setting EDID resolution".

Setting values

- on : Copy physical address
- oFF : Not copy physical address [Default]

Note:

CEC system link functions supported by other companies are not guaranteed to work correctly by this setting. Check the actual configuration.

8.2.16 [F42] Setting EDID WXGA

You can set the number of WXGA pixels based on the resolution setting of EDID.

The setting will be applied only if one of 03 to 46 is selected for "8.2.2 [F10] Setting EDID resolution".

Setting values

- on : 1366 × 768
- oFF : 1360 × 768 [Default]

8.2.17 [F70 to F7n] Setting audio output

You can set audio ON/OFF that is output from the HDMI output connectors.

Menu numbers

- F70 to F71 : OUT1 to OUT2 (VAC-2000UHD)
- F70 to F73 : OUT1 to OUT4 (VAC-4000UHD)

Setting values

- on : ON [Default]
- oFF : OFF

8.2.18 [F90] Displaying firmware version

You can display the firmware version.

8.2.19 [F99] Setting maintenance/status display menu

You can set the display setting of the maintenance menu and status display menu.

【8.1 Menu list】

Setting values

- oFF : [Default]
- on : At the next start-up, settings of "oFF" will be applied.
- ALL : Always displays

[Table 8.7] Displaying menu

Setting	Menu		
	Setting value	Maintenance	Status display
oFF	Displayed	Not displayed	Not displayed
on	*	*	*
ALL	Displayed	Displayed	Displayed

* At the time of the next start-up, settings of "oFF" will be applied.

8.3 Checking operation (Maintenance menu)

You can set necessary items for operation verification.

This menu is enabled and displayed by setting [F99] to "on" or "ALL".

To finish the operation, set the "SET" key.

8.3.1 [C01] Setting HDCP input

Some source devices check whether the connected device supports HDCP and then those source devices decide whether they encrypt HDCP signals or not.

Since the VAC is HDCP compliant, if it is connected to a display device that does not support HDCP, video may not be displayed. In these cases, the problem can be solved by setting this menu to "oFF".

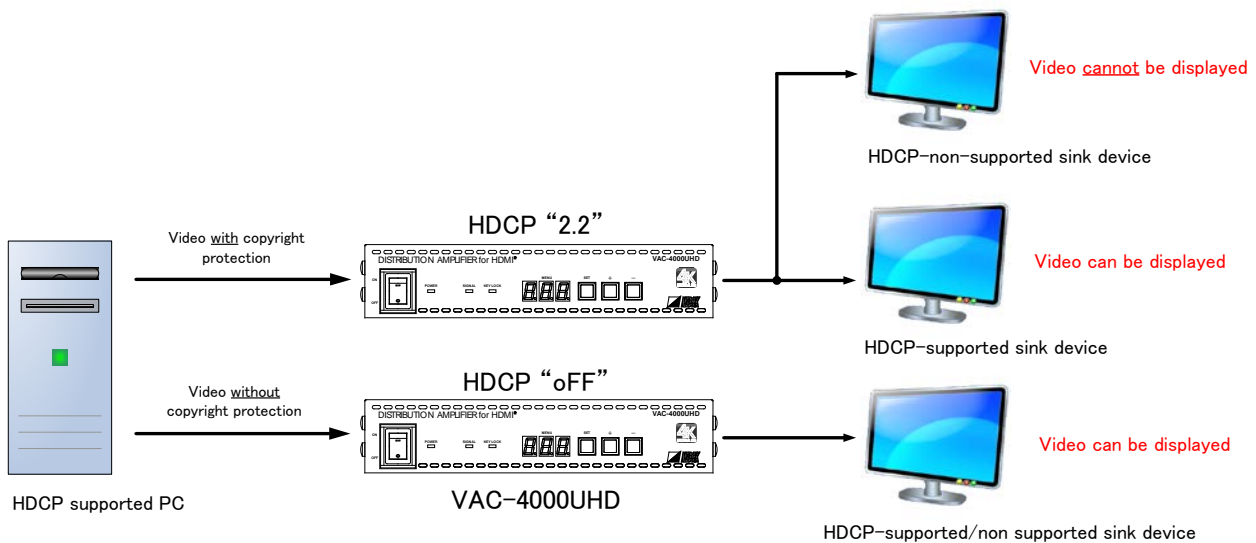

[Fig. 8.8] HDCP-supported and HDCP-non-supported display devices

Setting values

- 2.2 : Enable HDCP 2.2 encryption [Default]
- 1.4 : Enable HDCP 1.4 encryption
- oFF : Disable HDCP encryption

Notes:

- In order to display video whose copyright is protected, set this menu to "on".
- HDCP2.2 (stream type 0) contents can be displayed on sink devices supporting HDCP 2.2 / HDCP 1.4.
- HDCP2.2 (stream type 1) contents can be displayed on sink devices supporting HDCP2.2 but cannot be displayed on sink devices supporting HDCP1.4.

8.3.2 [C10 to C1n] Setting how long Hot plug is ignored

You can set the masking time to ignore video output requests that are sent from the sink device. If those signals are repeatedly sent from the sink device within a short cycle, the VAC tries to set the video output every time. As a result, video may not be output. In this case, video can be output correctly by setting this menu.

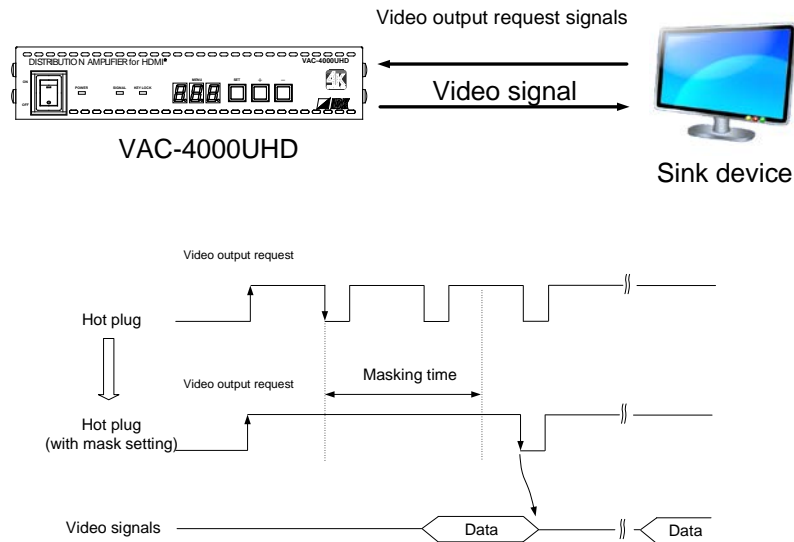

[Fig. 8.9] Hot plug ignorance time

Menu numbers

- C10 to C11 : OUT1 to OUT2 (VAC-2000UHD)
- C10 to C13 : OUT1 to OUT4 (VAC-4000UHD)

Setting values

- oFF : No masking [Default]
- 02 to 15 : 2 to 15 [second]

8.3.3 [C20 to C2n] Setting forced HDMI output mode

You can set how to check sink device EDID.

The VAC finds whether the sink device supports HDMI or DVI according to EDID acquired from the sink device and output appropriate video signals. However, if EDID cannot be acquired for some reason, the sink device type cannot be determined. In such a case, audio may not be output. To prevent or solve the problem, you can output the desired signals by setting this menu.

Menu numbers

C20 to C21: OUT1 to OUT2 (VAC-2000UHD)

C20 to C23: OUT1 to OUT4 (VAC-4000UHD)

Setting values

oFF : Determines the sink device is DVI when EDID cannot be read [Default]

Er1 : Determines the sink device is HDMI (without SCDC) when EDID cannot be read

AL1 : Always determines the sink device is HDMI (without SCDC)

Er2 : Determines the sink device is HDMI (with SCDC) when EDID cannot be read

AL2 : Always determines the sink device is HDMI (with SCDC)

Notes:

- If you want to use this menu other than default setting, set "8.2.2 [F10] Setting EDID resolution" to a value other than "01" (EXTERNAL) and set the resolution supported by the sink device.
- This menu is enabled when HDMI signals are input and the output mode is set to the value other than "DVI".

【8.3.4 [C30 to C3n] Setting output mode】

8.3.4 [C30 to C3n] Setting output mode

You can set the color space that will be sent to the sink device

The sink device automatically selects the appropriate color space according to the color space of the input video. If the sink device cannot do it for some reason, you can select the color space manually.

Menu numbers

C30 to C31 : OUT1 to OUT2 (VAC-2000UHD)

C30 to C33 : OUT1 to OUT4 (VAC-4000UHD)

Setting values

rgb : RGB output

422 : YCbCr 4:2:2 output

444 : YCbCr 4:4:4 output

d : DVI output

420 : YCbCr 4:2:0 output (Enabled only video is output at 4K@50 / 59.94 / 60. For other resolution, this menu is set to "oFF")

oFF : Automatic [Default]

Notes:

- This setting is applied only HDMI signals are input.
- If 4K format YCbCr 4:4:4 signals are input, the VAC automatically outputs signals at YCbCr 4:2:0 to YCbCr 4:2:0-supported (YCbCr 4:4:4 not supported) sink device.

8.4 Displaying input/output statuses (Status display menu)

Input and output statuses of the VAC can be displayed.

The status display menus can be operated by setting "8.2.19 [F99] Setting maintenance/status display menu" to "on" (Display) or "ALL" (Always display).

Press the "SET" key to exit the operation.

8.4.1 [L01 to L22] Displaying input information

[Table 8.8] Input information

Menu number	Displayed value	Description
● HDMI / DVI mode and color depth of input video		
L01	H08	HDMI 24 bit / pixel (8bit / component)
	H10	HDMI 30 bit / pixel (10bit / component)
	H12	HDMI 36 bit / pixel (12bit / component)
	d08	DVI 24 bit / pixel (8bit / component)
	- - -	No input
● HDCP of input video		
L02	on	with HDCP
	oFF	without HDCP
	- - -	No input
● HDCP authorization of input video (from the source device side)		
L03	1.4	with authorization (HDCP 1.4)
	2.2	with authorization (HDCP 2.2)
	oFF	without authorization
	- - -	No input
● Color space of input video		
L04	rgb	RGB
	422	YCbCr 4:2:2
	420	YCbCr 4:2:0
	444	YCbCr 4:4:4
	- - -	Unknown or no input
● Input video frequency		
L05	59.9	Input vertical synchronization frequency (with 59.9 Hz)
	- - -	No input
● DDC power supply		
L06	on	DDC powered on
	oFF	DDC powered off
● Input resolution		
L07	1920_1080P 60	Scroll display of input resolution (For 1920x1080p 60 Hz)
	- - -	No input

Menu number	Displayed value	Description
<p>The segment display is three digits. The first (left) two digits show the audio format, and third digit (X) shows the number of audio channels (1 = 2 channels, 2 = 2.1 channels, 5 = 5.1 channels, 7 = 7.1 channels).</p>		
L10	- - -	Unknown or no input
	00n	Unknown
	01n	PCM Audio
	02n	AC-3 Audio
	03n	MPEG-1 Audio
	04n	MP3 Audio
	05n	MPEG-2 Audio
	06n	AACLC Audio
	07n	DTS Audio
	08n	ATRAC Audio
	09n	DSD Audio
	10n	Dolby Digital Plus Audio
	11n	DTS-HD Audio
	12n	Dolby TrueHD Audio
	13n	DST Audio
14n	WMA Audio	
15n	HE-AAC / HE-AACv2 / MPEG Surround Audio	
<p>● Audio input sampling frequency</p>		
L11	22	22.05 kHz
	24	24 kHz
	32	32 kHz
	44	44.1 kHz
	48	48 kHz
	88	88.2 kHz
	96	96 kHz
	176	176.4 kHz
	192	192 kHz
	768	768 kHz
	_01	Unknown
	_05	
	_07	
	_11	
_13		
_15		
- - -	No input	

Menu number	Displayed value	Description
● Audio input bits, HBR (High Bit-Rate Audio)		
L12	H16	16 bit, HBR
	P16	16 bit, PCM
	_16	16 bit, Compressed audio other than HBR and PCM mode
	H20	20 bit, HBR
	P20	20 bit, PCM
	_20	20 bit, Compressed audio other than HBR and PCM mode
	H24	24 bit, HBR
	P24	24 bit, PCM
	_24	24 bit, Compressed audio other than HBR and PCM mode
- - -	No input	
● Audio input status (Digital audio)		
L13	000	No audio input
	001	Being input detecting
	002	Normal input
	- - -	No input
● Scrambling status of input signal		
L20	on	With scrambling (4K format except for YCbCr 4:2:0)
	oFF	No scrambling
	- - -	No input
● TMDS clock ratio of input signal		
L21	1_1	1/1
	1_4	1/4 (4K format except for YCbCr 4:2:0)
	- - -	No input
● Stream type of input signal (with HDCP 2.2)		
L22	000	Type 0
	001	Type 1
	non	HDCP1.4, or no HDCP signal
	- - -	No input

8.4.2 [L30 to Lbn] Displaying output information

[Table 8.9] Output information

Menu number	Displayed value	Description
● Deep Color: sink device status		
L30 to L3n*	08	24 bit / pixel (8 bit / component) supported
	10	30 bit / pixel (10 bit / component) supported
	12	36 bit / pixel (12 bit / component) supported
	- - -	Not connected
● Color space: sink device status		
L40 to L4n*	rgb	RGB supported
	422	YCbCr 4:2:2 supported
	444	YCbCr 4:4:4 supported (4K@50 / 59.94 / 60 (YCbCr 4:2:0) included)
	444_420	Scroll display Up to YCbCr 4:2:0 if the sink device resolution is 4K@50 / 59.94 / 60.
	- - -	Not connected
● Color space: output status		
L50 to L5n*	rgb	RGB output
	422	YCbCr 4:2:2 output
	420	YCbCr 4:2:0 output
	444	YCbCr 4:4:4 output
	- - -	Not connected
● Hot plug detection status		
L60 to L6n*	on	With Hot plug detection
	oFF	Without Hot plug detection
● HDMI / DVI sink device status		
L70 to L7n*	HC	HDMI (Compressed audio supported)
	HP	HDMI (PCM audio supported)
	d	DVI (Audio not supported)
	- - -	Not connected
● HDCP authorization		
L80 to L8n*	000	None
	001	Being authorized
	002	
	003	
	004	Authorization ended normally
	005	Authorization ended abnormally
● HDCP status		
L90 to L9n*	1.4	HDCP supported (HDCP 1.4)
	2.2	HDCP supported (HDCP 2.2)
	oFF	HDCP not supported or no HDCP signals
	- - -	Not connected

* VAC-2000UHD : n = 1, VAC-4000UHD : n = 3

Menu number	Displayed value	Description
● SCDC sink device		
LA0 to LAn*	on	SCDC supported
	oFF	SCDC not supported
	- - -	Not connected
● Scrambling output status		
Lb0 to Lbn*	on	With scrambling
	oFF	Without scrambling
	- - -	Not connected
● HDR sink device status		
Lc0 to Lcn*	on	HDR supported
	oFF	HDR not supported
	- - -	Not connected
● 3D sink device status		
Ld0 to Ldn*	on	3D supported
	oFF	3D not supported
	- - -	Not connected

* VAC-2000UHD : n = 1, VAC-4000UHD : n = 3

9 Specifications

9.1 Pin assignments

9.1.1 HDMI TypeA connector

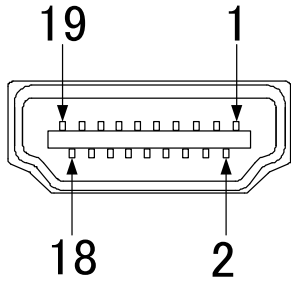

Pin #	Signal	Pin #	Signal
1	TMDS data2+	10	TMDS clock+
2	TMDS data2shield	11	TMDS clock shield
3	TMDS data2-	12	TMDS clock
4	TMDS data1+	13	CEC
5	TMDS data1shield	14	Backup (N.C.)
6	TMDS data1-	15	SCL
7	TMDS data0+	16	SDA
8	TMDS data0shield	17	DDC / CEC ground
9	TMDS data0-	18	+5 power supply
		19	Hot plug Detect

N.C.:No Connection

[Fig. 9.1] HDMI Type A pin assignments

9.2 Product specification

■ VAC-2000UHD

Item			Description
Input	Video	Digital	Number / Signal 1 input / HDMI, DVI 1.0 (HDCP 1.4 / 2.2) (*1) / HDR (*2) / 3D (*3) / x.v.Color - TMDS single link - TMDS clocks: 25 MHz to 300 MHz - Dot clocks: 25 MHz to 600 MHz - TMDS data rate: 0.75 Gbps to 18 Gbps
		Connector	1 female HDMI Type A
		Others	Color depth : 24 bit, 30 bit, 36 bit Deep Color (*5)
	Formats	VGA to 4K (*4) 480i / 480p / 576i / 576p / 720p / 1080i / 1080p / 4K (*4)	
	Audio	Digital	Number / Signal 1 input / Multi-channel LPCM up to 8 channels - Sampling frequency: 32kHz to 192kHz - Sample Size: 16bit to 24bit - Reference level: -20 dBFS - Max. input level: 0 dBFS
	Connector	1 female HDMI Type A	
Output	Video	Digital	Number / Signal 2 outputs / HDMI, DVI 1.0 (HDCP 1.4 / 2.2) (*1) / HDR (*2) / 3D (*3) / x.v.Color - TMDS single link - TMDS clocks: 25 MHz to 300 MHz - Dot clocks: 25 MHz to 600 MHz - TMDS data rate: 0.75 Gbps to 18 Gbps
		Connector	2 female HDMI Type A
		Others	Color depth : 24 bit, 30 bit, 36 bit Deep Color (*5)
	Formats	VGA to 4K (*4) 480i / 480p / 576i / 576p / 720p / 1080i / 1080p / 4K (*4)	
	Audio	Digital	Number / Signal 2 outputs / Multi-channel LPCM up to 8 channels - Sampling frequency: 32kHz to 192kHz - Sample Size: 16bit to 24bit - Reference level: -20 dBFS - Max. output level: 0 dBFS
		Connector	2 female HDMI Type A
	Analog	Number / Signal	1 output / Stereo L/R unbalanced signals (*6) - Output impedance: 75 Ω, - Reference level: -10 dBu - Max. output level: +10 dBu
Connector		1 RCA jack	
Plug & Play			DDC2B (built-in EDID / EDID copied from monitors / can be selected from EDID of connected monitors) Built-in EDID: the maximum resolution can be selected.
Max. Cable distance		Input	1080p@60: 131 ft. (40 m), 4K@60: 39 ft. (12 m) (*7)
		Output	1080p@60: 131 ft. (40 m), 4K@60: 39 ft. (12 m) (*7)
Functions	Contents Audio A/D and D/A conversion, Anti-snow (*8), De-embedded audio from HDMI signal, DDC buffer, 7 segment LED signal status check, Connection Reset (*9), Key lock		
Others	Power		100 - 240 VAC ± 10 %, 50 Hz/60 Hz ± 3 Hz
	Power consumption		About 8 Watts
	Dimensions		8.3 x 1.7 x 7.9" (210 (W) x 44 (H) x 200 (D) mm) (EIA 1U high, half rack wide) (Excluding connectors and the like)
	Weight		3.3 lbs. (1.5kg)
	Temperature		Operating: 32°F to 104°F / 0°C to +40°C Storage: -4°F to 176°F / -20°C to +80°C
Humidity		Operating / Storage humidity: 20 % to 90 % (Non Condensing)	

*1 ARC and HEC are not supported. CEC: Pass through between IN and OUT1

*2 HDR will be supported when you connect HDR supported corresponding sink device and select external EDID setting, or when you copy EDID of HDR supported sink device by selecting EDID copy setting. If the unit supports HRD, all output signals from the unit are HDR supported signals.

*3 3D will be supported when you connect 3D supported corresponding sink device and select external EDID setting, or when you copy EDID of 3D supported sink device by selecting EDID copy setting. If the unit supports 3D, all output signals from the unit are 3D supported signals.

*4 4K format: 24 Hz / 25 Hz / 30 Hz / 50 Hz (4:4:4) / 59.94 Hz (4:4:4) / 60 Hz (4:4:4) are supported.

*5 4K format: following color depth are supported.

- 24 Hz / 25 Hz / 30 Hz: 24 bit, 30 bit, 36 bit (RGB, YCbCr 4:4:4, YCbCr 4:2:2)
- 50 Hz / 59.94 Hz / 60 Hz : 24 bit, 30 bit, 36 bit (YCbCr 4:2:2, YCbCr 4:2:0)
: 24 bit (RGB, YCbCr 4:4:4)

*6 Analog audio output supports only 2 channel linear PCM.

*7 The maximum cable distance varies depending on the connected devices and was measured under following conditions:

- 1080p@60: when IDK's AWG24 cable was used and signals of 1080p@60 24 bit / pixel (8 bit / component) was input or output.
- 4K@60 : when IDK's 18 Gbps supported cable was used and signals of 4K@60 24 bit / pixel (8 bit / component) was input or output.

The maximum cable distance depends on the connected devices. The distance may not be extended with some device combinations, cabling method, or other manufacturer's cable. Video may be disturbed or may not be output even if signals are within the range mentioned above.

*8 The anti-snow feature automatically fixes snow noise that is a specific symptom of HDCP-compliant signals and mainly occurs at start-up. This feature does not work when snow noise has already occurred during startup or when it occurs due to a bad condition of the transmission line.

*9 For digital systems, some problems, such as an HDCP authentication error, can often be recovered by physically disconnecting and reconnecting the digital cables. However, the Connection Reset feature will fix these problems automatically without the need to physically plug and unplug the cables. It creates the same condition as if the cable were physically disconnected and reconnected. This feature only works for the MSD's output. If other devices are connected between the MSD's output and sink device, this feature may be invalid.

Problem	Check item	Page
	<p>[5] Is an unsupported resolution is input to the sink device? Check the resolution and video frequency. Some resolutions of sink device are not supported; check the specification of the sink device.</p>	35 [L07]
	<p>[6] Does the sink device support SCDC? ①Check the TMDS clock ratio of input signals. • 1_4: SCDC signals • 1_1: Not SCDC signals → This problem occurs due to another problem ②Check the SCDC supported status of the sink device. • on: SCDC is supported. • oFF: SCDC is not supported → video is not displayed.</p>	37 [L21] 39 [LAn]
	<p>[7] ①Check the stream type of input signals. • 000: Video is authorized to be displayed to all devices supporting HDCP 1.4,HDCP 2.2. • 001: Video is authorized to be displayed only to devices supporting HDCP 2.2. ②Check the HDCP supported status.</p>	37 [L22] 38 [L90]
	<p>[8] Change the setting of Hot plug ignoring time.</p>	32 [C1n]
	<p>[9] If a long cable is connected for input or output, replace it with a 5 meter/16.4 feet or shorter cable. A 5 meter/16.4 feet or longer cable can be connected for digital input/output for the VAC, but some cables fail HDCP authorization or EDID acquisition depending on the quality of the cable and connected devices. For 4K format, see “5 Sample application”.</p>	13
	<p>[10] Verify that No-signal input monitoring time ([F16]) is not short.</p>	24 [F16]
	<p>[11] Check the video output setting of the source device.</p>	—

Problem	Check item	Page
Interference or noise appears on video.	If a long cable is connected for input or output, replace it with a 16.4 ft./5 m or shorter cable. Even though a 5 m/16.4 feet cable can be connected since the VAC has compensation circuit for digital input and output, it cannot deliver its full performance depending on the cable quality and connected devices. If the problem is solved by the replacement with a shorter cable, the signals may have been deteriorated because of the long-distance transmission. IDK provides high-quality cables, boosters, and cable extenders. Please contact us as needed. For 4K format, see "5 Sample application".	13
	The transmission clock of Deep Color signals are faster than normal signals. If a poor-quality or long cable is connected when signals are input or output, noise may appear on the video. Deep Color can be controlled by the EDID setting.	25 [F20]
Video blinks.	If interlace signals are input to a sink device that does not support interlace signals, the video blinks. Check the supported resolution of the sink device.	20 [F10]
Video edges (up/down/right/left) are cut out.	Some sink devices display input video in overscan, and the video may be cut out. Check the display setting of the sink device.	—
Video is distorted horizontally or vertically.	Some sink devices display input video on full screen, and the aspect ratio cannot be kept. Check the display setting of the sink device. With some resolutions, full-screen display cannot be avoided. In that case, change the output resolution of the source device.	—
Black bars appear on PC images. Only part of the PC image is displayed, and the rest of the image is displayed by moving the mouse.	If the PC has the Panel Fit function, select "Scale Full Screen". If the resolution that is set for the PC and the resolution that is actually output from the PC are not matched, those problems may occur. Check the resolution of the PC and the EDID resolution setting.	20 [F10]
The dual monitor function cannot be set or it is canceled automatically.	When the No-signal input monitoring function works, the dual monitor function may not be enabled correctly. In this case, turn off this monitoring function.	24 [F16]

Problem	Check item	Page
● Audio output		
Video is displayed, but audio is not output.	Verify that audio output is turned on.	29 [F7n]
	If there are multiple output connectors in the source device, check the audio output setting of the source device.	—
	Verify that audio whose format is supported by the connected sink device is input. Especially, LCD monitors may not output 88.2 kHz or higher linear PCM and compressed audio (such as Dolby Digital and DTS). In order to play a Blu-ray disc having compressed audio, check the audio output setting of the source device. You can also control audio signals that will be output from the source device by setting EDID.	25 [F22] to 27 [F34]
	Verify that DVI signals are not being output from the source device.	—
Even though multi-channel audio is played, only audio signals of 2 channels are output.	For multiple channel play, change the EDID setting which is set to 2 channels by default.	28 [F36]
Audio is output from HDMI output, but it is not output from analog audio output.	If compressed audio (such as Dolby Digital and DTS) is input, analog audio is not output. Only 2-channel linear PCM is supported for analog audio output.	25 [F22] to 27 [F34]
Audio is output from analog audio output, but it is not output from HDMI output.	Verify that audio output is set to ON.	29 [F7n]
	Verify that audio can be output by the connected sink device with the selected resolution. If an output resolution for PCs (VGA to WQXGA is selected, the sink device may not output audio.	20 [F10]
	Verify that the selected sampling frequency is supported by the connected sink device. Some LCD monitors cannot output high-sampling frequency audio (88.2kHz or higher). Audio signals output from the source device can be controlled by setting EDID.	25 [F22] to 27 [F34]
Compressed audio (such as Dolby Digital and DTS) is not output from the source device.	Inputting compressed audio is limited by the EDID setting(factory default). In order to use compressed audio, change the EDID setting.	25 [F22] to 27 [F34]
	Check the audio output setting of the source device.	—
● Others		
Devices cannot be controlled by CEC.	If you use CEC, enable the HDMI link control function of devices to be connected to the VAC, such as LCD TVs and Blu-ray disk recorders.	—
	Connect the desired sink device to OUT1. If connecting to another connector, the device cannot be controlled.	—

If additional assistance is required, please perform the following tests and then contact us.

1. The problem occurs in all connectors?
2. Connect devices using genuine cables without connecting the VAC
(no VAC between the source and display devices).

User's Guide of VAC-2000UHD / 4000UHD

Ver.1.3.0

Issued on: September 5, 2018



Headquarters IDK Corporation
7-9-1 Chuo, Yamato-shi, Kanagawa-pref.
242-0021 JAPAN
TEL: +81-46-200-0764 FAX: +81-46-200-0765
Email: idx_eng@idx.co.jp URL: <http://www.idx.co.jp/en/index.html>

USA IDK America Inc.
72 Grays Bridge Road Suite 1-C, Brookfield, CT 06804
TEL: +1-203-204-2445
Email: info@idxkav.com URL: <http://www.idxkav.com>

Europe IDK Europe GmbH
Lise-Meitner-Str. 6, D-40878 Ratingen
TEL: +49-2102-578-301-0
Email: info@idxkav.eu URL: <http://www.idxkav.eu>



Product information Arvanics Corporation
Support 3-8-3-3F Yamato Higashi, Yamato-shi, Kanagawa-pref.
242-0017 JAPAN
TEL: +81-46-259-6920 FAX: +81-46-259-6930
Email: info@arvanics.com URL: <http://www.arvanics.com>

Information in this document is subject to change without notice.
All rights reserved. All trademarks mentioned are the property of their respective owners.