



The TROLLEY™ E

Dimensions are for underneath side of worksurface. Product specifications are subject to change without notice. Dimensions are nominal.

MAXIMUM DIMENSIONS / WEIGHT FOR FLAT PANEL DISPLAY (EXCLUDING BASE)

- 23¼" D x 18 1/2" W x 14" H (70mm x 470mm x 356mm)
- Fits most monitors up to 21" diagonal or 20" widescreen
- Weight cannot exceed 21 lbs.

Shipping box dimensions and weight: 10"D x 26"W x 26"H – 32lbs

- Minimum work surface depth: 24"
- Minimum kneespace width: 25"
- Minimum work surface height: 28"
- Work surface footprint: 24 1/2" W x 8 1/2" D
- Work surface cut-out 24 3/32" W x 7 7/8" D
- Maximum distance from center of wall mount VESA plate to bottom of monitor is 6 3/4" (171mm)

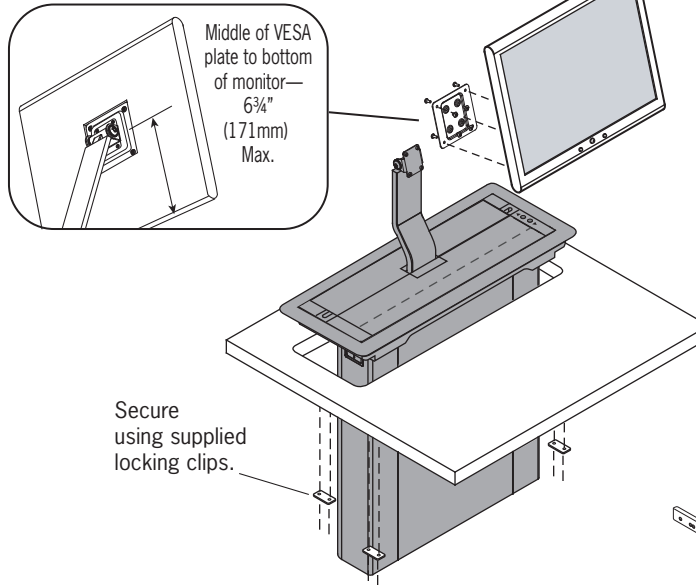
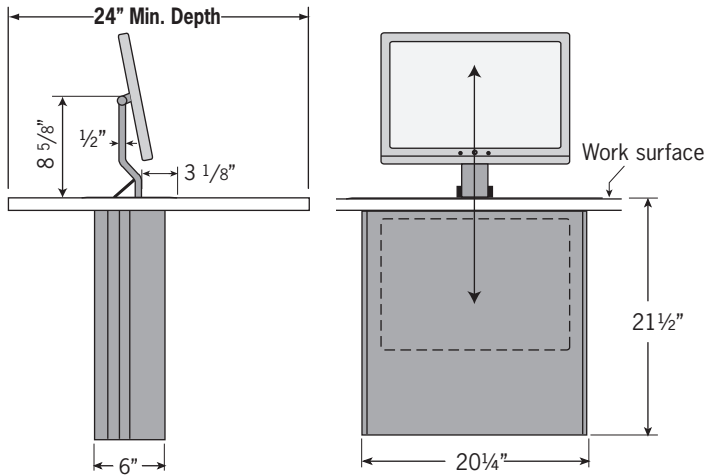

FEATURES

TROLLEY E

Low voltage electrical motor to lift and lower monitor. Display submerges into desktop when not in use. Intelligent Motion Technology™ provides operational intuition. Tamper guard security hardware. Provides vertical tilt adjustment in "up" position. Access doors automatically open and close. Secure to worksurface using locking clips underneath.

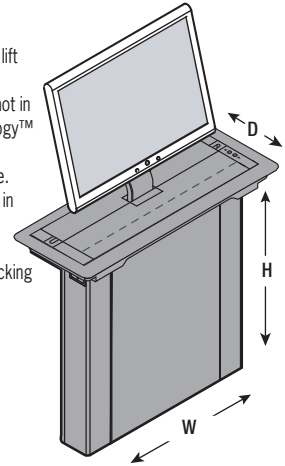

KEYBOARD DRAWER

Textured black thermoformed ABS keyboard drawer features soft radius edges. Five positive inward and outward stop locations. Outward locking tabs prevent accidental removal of keyboard drawer.

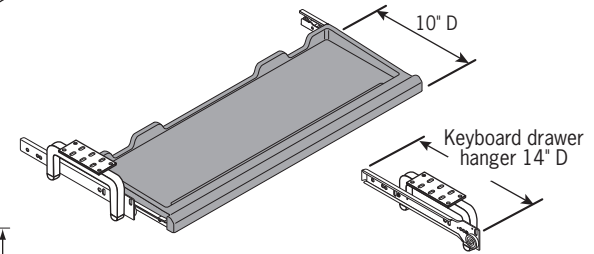

Keyboard Size	Dimension A — Min. Kneespace Width	Dimension B — Keyboard Drill Pattern
22"	22" (559 mm)	18 13/16" (478 mm)
24"	25 7/8" (657 mm)	22 19/32" (574 mm)
27"	28 5/8" (727 mm)	25 5/16" (643 mm)
28"	29 1/2" (749 mm)	26 1/8" (663 mm)
30"	31 5/8" (803 mm)	28 1/16" (712 mm)
33"	34 5/8" (879 mm)	31 1/4" (793 mm)
34"	35 1/2" (902 mm)	32 1/8" (815 mm)

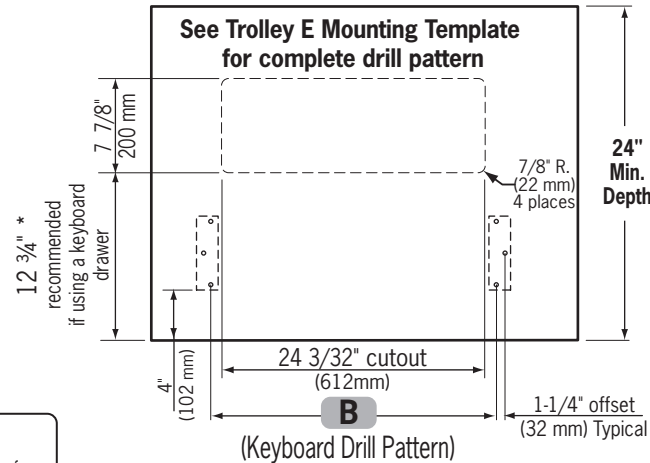
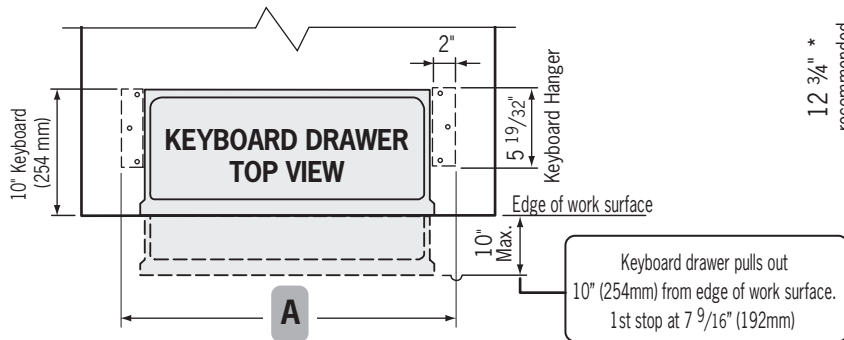

* Note: If using a 22" width keyboard tray, Trolley must be set back a minimum of 15"