

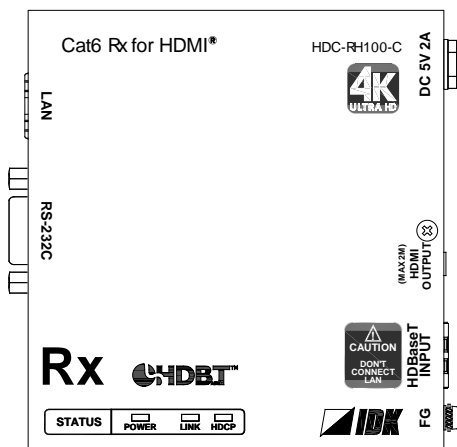

HDMI Twisted Pair Extender HDC-TH100-C/HDC-RH100-C

User's Guide Ver. 1.0.0

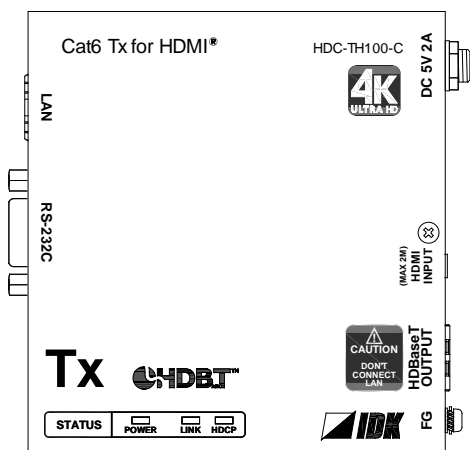

- Thank you for choosing this IDK product.
- To ensure the best performance of this product, please read this User's Guide fully and carefully before using it and keep this manual beside this product.

Trademarks

- The terms HDMI and HDMI High-Definition Multimedia Interface, and the HDMI Logo are trademarks or registered trademarks of HDMI Licensing, LLC in the United States and other countries.
- HDBaseT™ and the HDBaseT Alliance Logo are trademarks of the HDBaseT Alliance.
- All other company and product names mentioned in this manual are either registered trademarks or trademarks of their respective owners. In this manual, the “®” or “™” marks may not be specified.

Before reading this manual

- All rights reserved.
- Some of the contents in this User's Guide such as appearance diagrams, menu operations, communication commands, and so on may differ depending on the version of the extender.
- This User's Guide is subject to change without notice. You can download the latest version from IDK's website at: <http://www.idk.co.jp/en/index.html>

FCC STATEMENT

This equipment has been tested and found to comply with the limits for a Class A digital device, pursuant to part 15 of the FCC Rules. These limits are designed to provide reasonable protection against harmful interference when the equipment is operated in a commercial environment. This equipment generates, uses, and can radiate radio frequency energy and, if not installed and used in accordance with the instruction manual, may cause harmful interference to radio communications. Operation of this equipment in a residential area is likely to cause harmful interference, in which case the user will be required to correct the interference at his own expense.

Note: This equipment was tested with shielded cables on the peripheral devices. Shielded cables must be used with the equipment to ensure compliance with FCC emissions limits.

CE MARKING

This equipment complies with the essential requirements of the relevant European health, safety and environmental protection legislation.

WEEE MARKING











Waste Electrical and Electronic Equipment (WEEE), Directive 2002/96/EC
(This directive is only valid in the EU.)

This equipment complies with the WEEE Directive (2002/96/EC) marking requirement.
The left marking indicates that you must not discard this electrical/electronic equipment in domestic household waste.

Safety instructions







Read and understand all safety and operating instructions before using this product. Follow all instructions and cautions as detailed in this document.

Enforcement Symbol	Description
 Warning	Indicates the presence of a hazard that may result in death or serious personal injury if the warning is ignored or the equipment is handled incorrectly.
 Caution	Indicates the presence of a hazard that may cause minor personal injury or property damage if the caution is ignored or the equipment is handled incorrectly.





Symbol	Description	Example
 Caution	This symbol is indicated to alert the user. (Warning and caution)	 Electrical Hazard
 Prohibition	This symbol is intended to prohibit the user from actions.	 Do not disassemble
 Instruction	This symbol is intended to instruct the user.	 Unplug



Warning

 <p>Prohibition</p>	<p>Do not place the product in any unstable place. Install the product to a horizontal and stable place. Otherwise, it may fall/turn over and lead to injury.</p>
	<p>Do not place the product in any environment with vibration. Otherwise, it may move/fall and lead to injury.</p>
	<p>Keep out any foreign objects. In order to avoid fire or electric shock, do not allow foreign objects, such as metal and paper, to enter the product from the vent holes.</p>
	<p>For power cable/ plug:</p> <ul style="list-style-type: none"> • Do not scratch, heat, or modify, including extending them. • Do not pull, put heavy stuff on them, or pinch them. • Do not bend, twist, or tie them together forcefully. <p>If they are used in those states continuously, it may cause fire or electric shock. If power cables/plugs become damaged, contact IDK.</p>
 <p>Do not disassemble</p>	<p>Do not repair, modify or disassemble. Since the product includes high-voltage parts, those actions may cause fire or electric shock. For internal inspections or repairs, contact IDK.</p>
 <p>Do not touch</p>	<p>In the event of lighting or thunder, do not touch the main unit or cables such as power cable and LAN cable. Contact may cause electric shock</p>
 <p>Instruction</p>	<p>For installation: The product is intended to be installed by skilled technicians. For installation, please contact a system integrator or IDK. Otherwise, it may cause fire, electric shock, injury, or property damage.</p>
	<p>Set the power plug in a convenient place to unplug easily. You can easily unplug in case of any extraordinary failure or abnormal situation, and it also helps for unplugging when you do not use it for a long period.</p>
	<p>Plug the power plug into appropriate outlet completely. If the plug is plugged incompletely, it may overheat which causes electrical shock or fire. Do not use damaged plug or loosened outlet.</p>
	<p>Clean the power plug regularly. If the plug is covered in dust, it may cause fire due to reduced insulating power.</p>
 <p>Unplug</p>	<p>Unplug immediately if the product smokes, makes unusual noise, or smells. If you continue to use the product under those situations, it may cause electric shock or fire. After confirming that the product stops smoking, contact IDK.</p>
	<p>Unplug immediately if you drop the product or if the cabinet is damaged. If you continue to use the product under those situations, it may cause electrical shock or fire. For maintenance and repair, contact IDK.</p>
	<p>Unplug immediately if water or other objects are directed inside. If you continue to use it under those situations, it may cause electrical shock or fire. For maintenance and repair, contact IDK.</p>
<p>For connection</p>	
 <p>Instruction</p>	<p>Differences in ground potential among the product and peripheral devices may cause electric shock or damage of the devices. When using cables to connect devices, including connection of long-distance transmission, unplug the power cables of all related devices. After connecting signal/control cables of each device, plug in the power cables of each device.</p>

Caution

 Prohibition	<p>Do not place the product in any place where it will be subjected to high temperatures. If the product is subjected to direct sunlight or high temperatures, it may cause fire.</p>
	<p>Do not place the product in humid, oil smoke, or dusty place. If the product is placed near humidifiers or dusty area, it may cause fire or electric shock.</p>
	<p>Do not block the vent holes. If ventilation slots are blocked, it may cause fire or failure due to internal heat.</p>
	<p>Do not put heavy items on the product. It may fall/turn over and lead to injury.</p>
	<p>Do not exceed ratings of outlet and wiring devices. If several plugs are put in an outlet, it may cause fire and electric shock.</p>
	<p>Use only the provided AC adapter and power cable. If non-compliant adapter or power cables is used, it may cause fire or electrical shock. Use the provided AC power connection cable. If you want to use your product in other countries that use different AC power cables, contact IDK.</p>
 No wet hands	<p>Do not plug or unplug with wet hands. It may cause electrical shock.</p>
 Instruction	<p>Use and store the product within the specified temperature/humidity range. If the product is used outside the range continuously, it may cause fire or electric shock.</p>
	<p>Turn off devices when they are connected to another device. It may cause fire or electric shock.</p>
 Unplug	<p>Unplug the power plug if you do not use the product for a long period. In case of defect, it may cause fire.</p>
	<p>Unplug the power plug before cleaning. It may cause electric shock.</p>

For installation

For rack mount devices:

 Instruction	<p>Mount the product to the rack meeting EIA standards, and maintain spaces above and below for air cooling. For your safety, attach an L-shape bracket in addition to the mount bracket kit for the front panel in order to balance the weight.</p>
---	--

For devices with rubber feet:

 Instruction	<p>Never insert only the screws into the holes after removing the rubber feet. It may lead to damage when the screws contact electrical circuit or parts inside of the product. To put the rubber feet back on, use only provided rubber feet and screws.</p>
---	---

Altitude:

 Instruction	<p>Do not place the product at elevations of 2,000 meters (6562 feet) or higher above sea level. Failure to do so may shorten the life of the internal parts and result in malfunctions.</p>
---	--

Table of Contents

1	Included items	8
2	Product Outline.....	9
3	Features	10
4	Part names and descriptions.....	11
4.1	Transmitter (HDC-TH100).....	11
4.2	Receiver (HDC-RH100).....	12
5	Connecting external devices	13
5.1	Preparation	13
5.2	Precautions.....	14
5.2.1	Installation	14
5.2.2	Cabling.....	14
5.2.3	Twisted pair cable for extension	15
5.2.4	Precautions for RS-232C communication.....	15
5.2.5	DVI signals with copyright protection.....	16
5.2.6	Cascade connection	16
5.3	Application example	17
6	Specifications	18
6.1	Pin assignments	18
6.1.1	HDMI Type A connector.....	18
6.1.2	RJ-45 connector.....	18
6.1.3	RS-232C connector	19
6.2	Product Specifications	20
7	Troubleshooting.....	22

1 Included items

Make sure all items below are included in the package.

If any items are missing or damaged, please contact IDK.

“HDC” or “HDC-H100” mentioned in this manual refers to HDC-TH100 and HDC-H100 set.

■ Transmitter

- HDC-TH100 (main unit) x1
- AC adapter with screw type lock (1.2 m/3.94 feet) x1
- Cable clamp x1

■ Receiver

- HDC-RH100 (main unit) x1
- AC adapter with screw type lock (1.2 m/3.94 feet) x1
- Cable clamp x1

This User's Guide is common to both the transmitter and receiver. You can download the latest version from IDK's website at: <http://www.idk.co.jp/en/index.html>

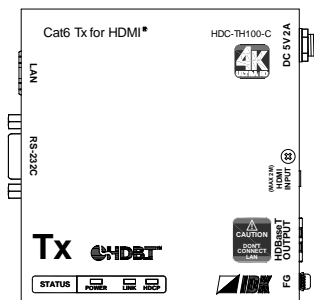

HDC-TH100 (main unit)

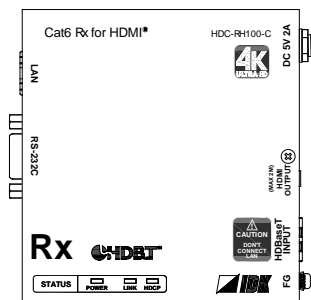

HDC-RH100 (main unit)

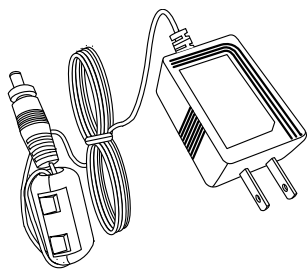

AC adapter with screw type lock
(1.2 m/3.94 feet)

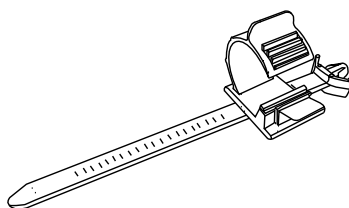

Cable clamp

[Figure 1.1] List of included items

2 Product Outline

The HDC-TH100/HDC-RH100 (hereafter referred to as "HDC") is an HDMI extender (transmitter and receiver set) for long-distance transmission over twisted pair cables, and it supports 4K@60 (4:2:0). Digital video signals are transmitted without conversion to analog signals.

The HDC supports RS-232C serial bidirectional communication and LAN transmission.

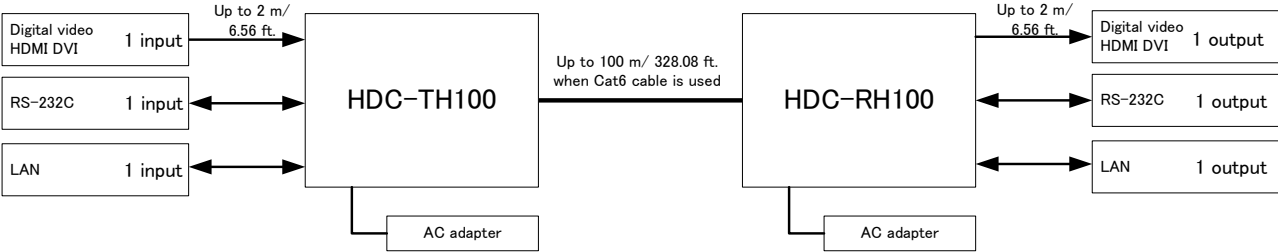

[Figure 2.1] Application diagram

3 Features

- Video
 - 4K@60 (4:2:0)
 - HDCP 1.4/2.2 (pass through)
 - Extension: up to 100 m/328.08 feet (4K@60) using Cat6/Cat5e STP cables up to 100 m/328.08 feet using Cat6 UTP cables^{*1}
 - Transmission using Cat5e UTP cables is also available.^{*2}
 - No substantive transmission delay (10 μ s or less per 100 m/328.08 feet)

- Others
 - CEC (pass through)
 - HDMI signals can be extended using twisted pair cables.
 - The AC adapter has a locking mechanism.

^{*1} For 70 m/229.65 feet or longer 4K formats, Cat6 STP cable and Cat5e STP cable are recommended.

^{*2} For 50 m/164.04 feet or longer, Cat6 UTP cable is recommended.

- CEC (Consumer Electronics Control):
Device control protocol defined in HDMI 1.0 specification.
This protocol controls multiple devices connected via HDMI cables using a remote control.

4 Part names and descriptions

4.1 Transmitter (HDC-TH100)

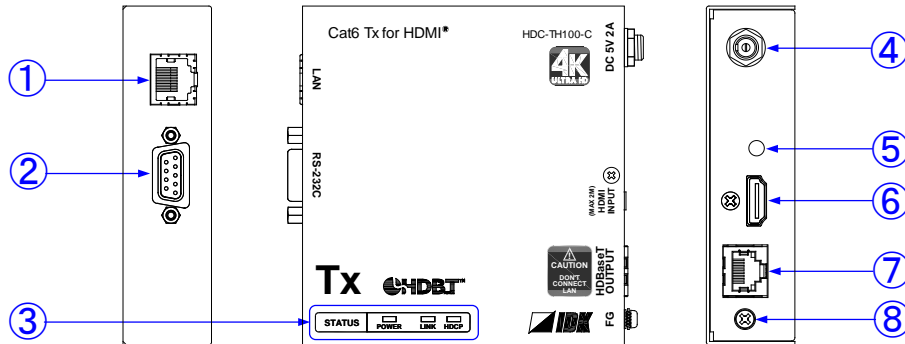

[Figure 4.1] Panel drawing (HDC-TH100)

[Table 4.1] Item descriptions (HDC-TH100)

#	Part name	Description
①	LAN port	Port for LAN signals
②	RS-232C port	Port for RS-232C signals
③	LED lights	<p>POWER (Green): Lights when power is supplied from the AC adapter.</p> <p>LINK (Orange): Lights when an HDC receiver is connected. Blinks (0.5 second-interval) when the destination is in standby state. LAN and RS-232C communications are available. Turns off when no connection.</p> <p>HDCP (Yellow): Lights when there is an access to HDCP. Blinks when there is no access to HDCP. Turns off when no input signals are recognized.</p>
④	AC adapter connector	Connector for the supplied AC adapter.
⑤	Cable fixing hole	Hole for the supplied cable clamp to secure the HDMI cable
⑥	HDMI input connector	Input connector for HDMI signals Connect to source devices such as Blu-ray disk players.
⑦	Connector for long-haul extension	Output connector for HDBaseT signals. Connected to the receiver of the HDC series.
⑧	Frame ground	Ground terminal

4.2 Receiver (HDC-RH100)

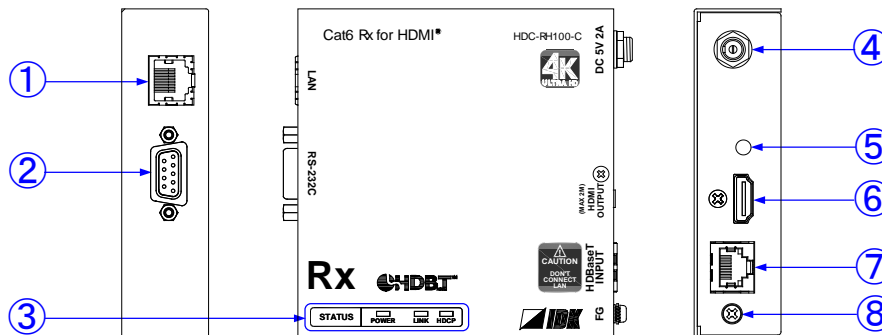

[Figure 4.2] Panel drawing (HDC-RH100)

[Table 4.2] Item descriptions (HDC-RH100)

#	Part name	Description
①	LAN port	Port for LAN signals
②	RS-232C port	Port for RS-232C signals
③	LED lights	<p>POWER (Green): Lights when power is supplied from the AC adapter.</p> <p>LINK (Orange): Lights when an HDC transmitter is connected. Blinks (0.5 second-interval) when the destination is in standby state. LAN and RS-232C communications are available. Turns off when no connection.</p> <p>HDCP (Yellow): Lights when there is an access to HDCP. Blinks when there is no access to HDCP. Turns off when any input signals are not recognized.</p>
④	AC adapter connector	Connector for the supplied AC adapter.
⑤	Cable fixing hole	Hole for the supplied cable clamp
⑥	HDMI output connector	Output connector for HDMI signals Connect sink devices such as TV and projector.
⑦	Input connector for extension	Output connector for HDBaseT signals. Connected to the transmitter of the HDC series.
⑧	Frame ground	Ground terminal

5 Connecting external devices

5.1 Preparation

Before connecting an external device, such as a source device and the sink device, please prepare the required cables.

- 2 m/6.56 ft. or shorter HDMI cable (Type A 19 pin plug)
- Twisted pair cable for extension (UTP/STP cable meeting Cat5e/Cat6)
- LAN cable meeting 10Base-T/100Base-TX
- RS-232C cable (D-sub9 pin, female)

- **HDMI cable:** 2 m/6.56 feet or shorter HDMI cables with Type A (male) connector whose pins are configured correctly

[Flexible cable]

For input/output cable, please use one of the following cables.

Model number	Length
HDSS-005	0.5 m/1.64 ft.
HDSS-01	1.0 m/3.28 ft.
HDSS-02	2.0 m/6.56 ft.

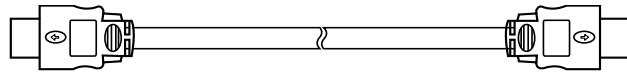

[Conversion cable]: HDMI-DVI conversion cable

Model number	Length
HDSS-DMHM-005	0.5 m/1.64 ft.
HDSS-DMHM-01	1.0 m/3.28 ft.
HDSS-DMHM-02	2.0 m/6.56 ft.

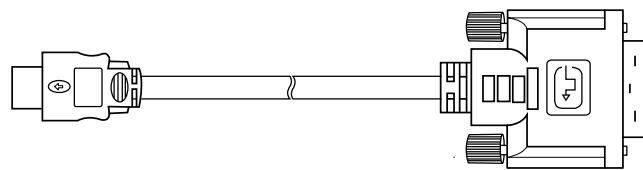

- **Twisted pair cable for extension:** UTP/STP cable meeting Cat5e/Cat6 standard
[See “6.1.2 RJ-45 connector”]
- **LAN cable:** meeting 10Base-T/100Base-TX standard
100-Mbps Ethernet signals can be transmitted over a long distance.
[See “6.1.2 RJ-45 connector”]
- **RS-232C cable:** D-sub 9 pin, female
RS-232C signals (115.2 Kbps at a maximum) can be transmitted in duplex over a long distance.
Select a cross cable or straight cable according to the connected devices.
[See “6.1.3 RS-232C connector”]

5.2 Precautions

Before connecting external devices, follow the precautions below.

5.2.1 Installation

- In order to connect cables to this product or to devices connected to this product, first remove static electricity by touching grounded metal such as racks before handling the cables. Otherwise it may cause a malfunction.
- Do not place the transmitter on top of the receiver and vice versa.
- Do not block vent holes. Please secure the space above ambient 30 mm/1.18 inches.
- Do not install the HDC in closed space.

If you have to install this product in closed space, install an additional ventilation space in order to keep the ambient temperature at 40 degrees C/104 degrees F or less. (Exception: Installing to IDK's Quarter rack, RM-42HQ) If inadequately vented, the life of parts may be shortened and operations may be affected.

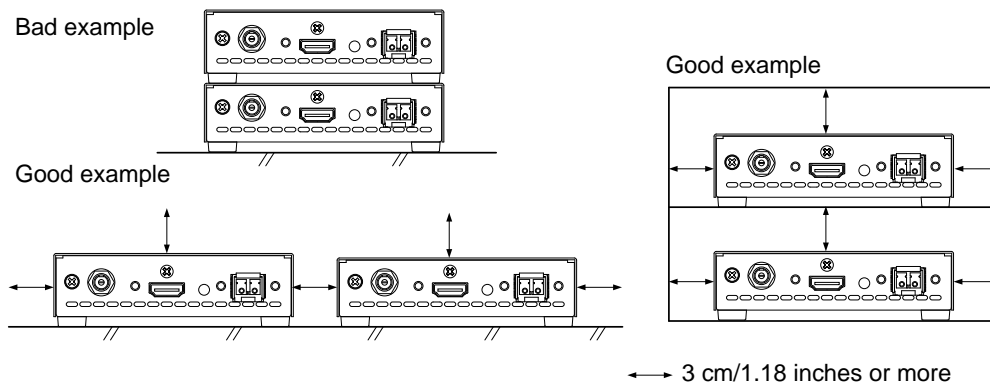

[Figure 5.1] Space required for installation

5.2.2 Cabling

- Read the instruction manuals of the external devices carefully.
- Turn off the transmitter/receiver before connecting cables.
- Insert the cable into the connector firmly and do not give the connector stress.
- Secure the HDMI cable using a cable clamp in order to prevent it from falling off the HDC.

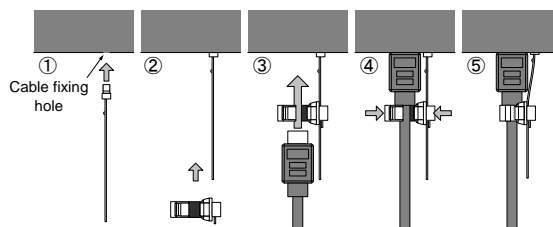

[Figure 5.2] Attaching cable clamp

5.2.3 Twisted pair cable for extension

The connector for a long-haul transmission is the same as the 8-core modular connector that is used for Ethernet. However, it cannot connect to Ethernet since the transmission method is not the same.

To ensure the best performance, select and connect the proper twisted pair cable correctly.

- We recommend a Cat6 UTP/STP cable for the twisted pair cable between the transmitter and receiver. If using an STP cable, connect the FG connector to a ground source. Otherwise, the shielding feature does not work correctly. When using a UTP cable, we still recommend using the ground connector.
- For 50 m/ 164.04 feet or shorter transmissions, Cat5e UTP cable can be used.
- The shielded STP cables are less affected by interference or external noise than UTP cables.
- The maximum extension distance of Cat5e/Cat6 UTP/STP cable is the shortest distance of maximum extension distances of HDC transmitter, HDC receiver and sink device.
- For pin assignments apply T568A or T568B standards for straight through cabling.
- Do not give connection cables a strong pull. The allowable tension of the twisted pair cable is 110 N.
- Do not bend the connection cable at a sharp angle. Keep the bend radius four times of the cable diameter or larger.
- Do not tie the cable tightly; leave a space allowing the cable to move slightly.
- If you use the same cables, we recommended keeping a distance between the cables or not to place the cables closely in parallel.
- Keep the twisted pair cable as straight as you can. If you coil the cable, it is easily affected by noise.
- Do not place this product in an electrically noisy environment, since high-speed signals are transmitted. Particularly when you use a high-output radio around the HDC, video or audio may be interrupted.
- If the distance between the transmitter and receiver is 100 m/328.08 feet or less, cables can be joined using an RJ-45 plug coupler or wall outlet. Up to two cable couplers are allowed and couplers supporting Cat6A (10GBase-T) are recommended.
- The table below shows supported extension distance for each twisted pair cable category. Note that the distance may shorten depending on the actual environment.

Category	Extension distance	Dot clock	Remarks
Cat5e	50 m/164.04 ft.	<=225 MHz	For 50 m/164.04 ft. or longer, Cat6 is recommended
Cat6	100 m/328.08 ft.		
	70 m/229.66 ft.	>225 MHz (4K format)	For 70 m/229.66 ft. or longer, Cat6 STP/Cat5e STP is recommended
Cat5eSTP Cat6STP	100 m/328.08 ft.		

Note: If there is a problem in the transmission path, video or audio may be interrupted. Please check the items above. If the problem still cannot be solved, shorten the length of the twisted pair cable.

5.2.4 Precautions for RS-232C communication

When designing a control program, please note the following points:

- For RS-232C communication, unnecessary data may be input to RS-232C signals when the HDC is turned off or the link is established.
- The control by RS-232C communication is not available until the link is established.

5.2.5 DVI signals with copyright protection

The HDC does not support the long-distance transmission of DVI signals that are protected by HDCP (hereafter referred to as "DVI signals with HDCP"). Use our HDC-D100 extender that supports DVI signals for transmission over twisted pair cable signals providing HDCP support.

	With HDCP*	Without HDCP
HDMI signals	Supported	Supported
DVI signals	Not supported	Supported

* Depends on the combination of source and sink devices

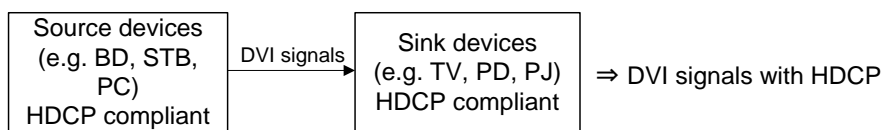

[Figure 5.5] Configuration example of DVI signals with HDCP

If both source and sink devices have an HDMI connector, HDMI signals are output; if either or both have a DVI connector, DVI signals are output. However, even if both connectors are for HDMI, sometimes DVI signals will still be output. Note that signal type to be output cannot be determined only by connector shapes.

Example: DVI signals are output even when a projector with an HDMI connector is connected. Some source devices will check the EDID of the projector, and if the audio is not compliant, DVI signals will be output instead of HDMI.

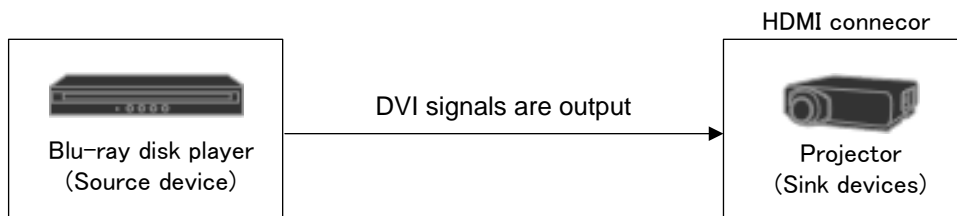

[Figure 5.6] Example: DVI signals are output between HDMI connectors

5.2.6 Cascade connection

Distribution amplifiers and multi switchers that are HDCP-compliant repeaters can be connected, and can be configured in a cascade connection using IDK's HDC-D100 twisted pair cable extender that supports DVI signals. However, cascade connection is not available in the following cases:

- HDC-TH/RH100 and another set of HDC-TH/RH100 (IDK's twisted pair cable extender supporting HDMI signals)
- A repeater that only supports HDCP pass through (Example: Switchers, boosters)

5.3 Application example

Video and audio digital signals are transmitted from the Blu-ray disc player to the transmitter. The transmitter sends these signals to the receiver through a twisted pair cable for extension while the receiver outputs the received video and audio signals from the HDMI output connector to the projector. Projectors and similar devices can be controlled using control devices such as PCs.

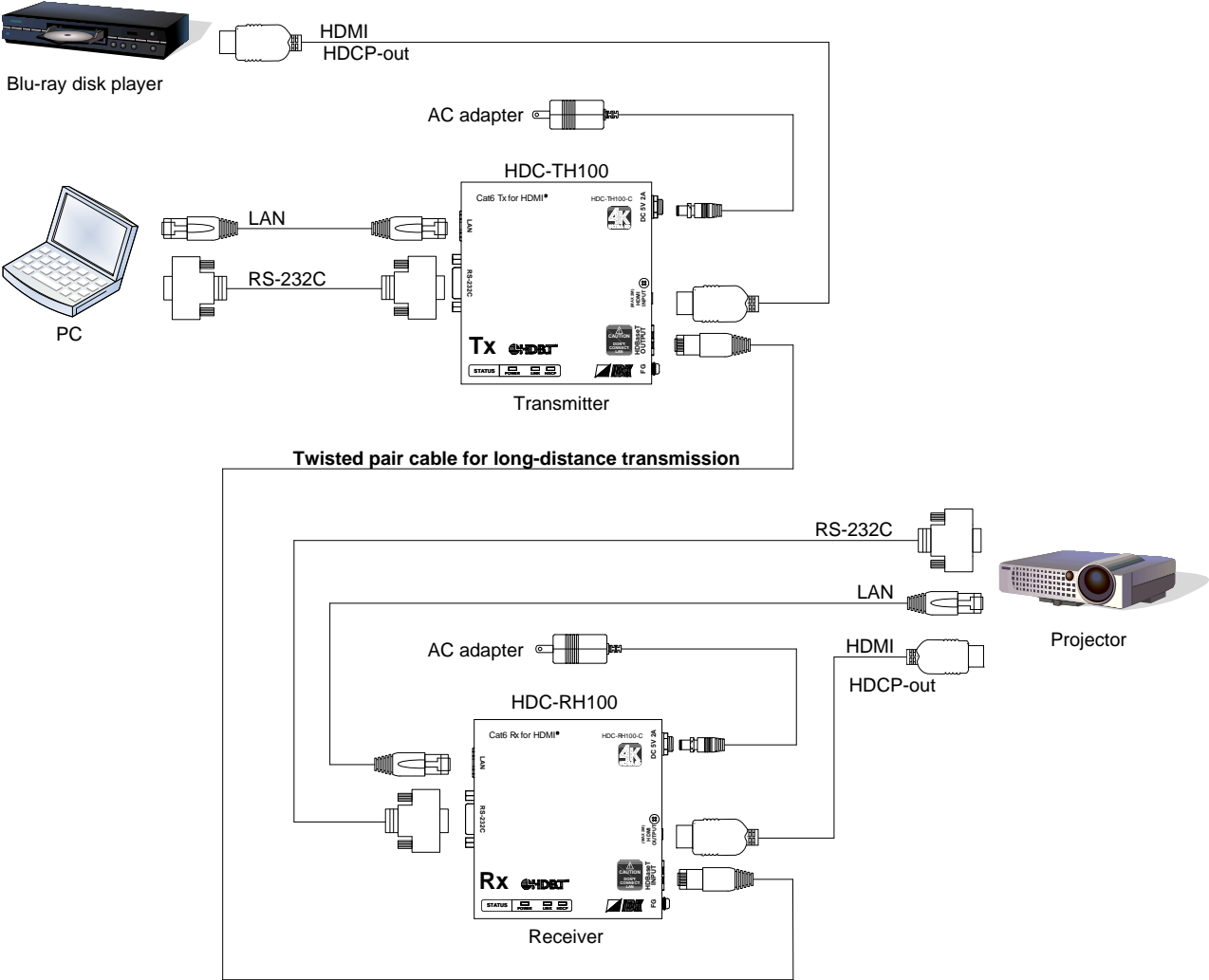

[Figure 5.7] Configuration example

6 Specifications

6.1 Pin assignments

6.1.1 HDMI Type A connector

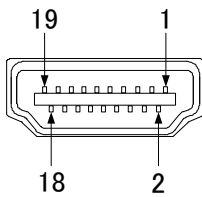

Pin number	Signal	Pin number	Signal
1	TMDS Data2+	10	TMDS Clock+
2	TMDS Data2 Shield	11	TMDS Clock Shield
3	TMDS Data2-	12	TMDS Clock-
4	TMDS Data1+	13	CEC
5	TMDS Data1 Shield	14	Reserved (N.C.*)
6	TMDS Data1-	15	SCL
7	TMDS Data0+	16	SDA
8	TMDS Data0 Shield	17	DDC/CEC Ground
9	TMDS Data0-	18	+5 V Power
		19	Hot plug Detect

*N.C. : No Connection

[Figure 6.1] HDMI Type A pin assignments

6.1.2 RJ-45 connector

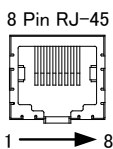

TIA/EIA-568A		TIA/EIA-568B	
Pin number	Signal	Pin number	Signal
1	WHITE/GREEN, Stripe	1	WHITE/ORANGE, Stripe
2	GREEN	2	ORANGE
3	WHITE/ORANGE, Stripe	3	WHITE/GREEN, Stripe
4	BLUE	4	BLUE
5	WHITE/BLUE, Stripe	5	WHITE/BLUE, Stripe
6	ORANGE	6	GREEN
7	WHITE/BROWN, Stripe	7	WHITE/BROWN, Stripe
8	BROWN	8	BROWN

[Figure 6.2] RJ-45 pin assignments

6.1.3 RS-232C connector

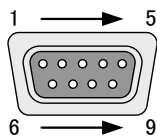

RS-232C connector
D-sub 9 pin male

■ **Connecting to a PC:**

For RS-232C cable, make sure to use a cross cable.

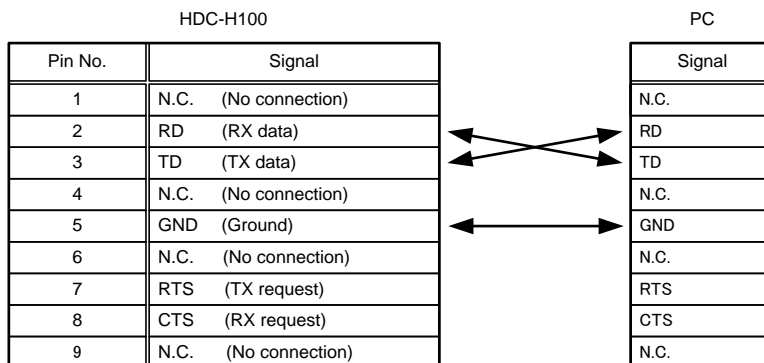

■ **Connecting to an IDK's product:**

For RS-232C cable, make sure to use a cross cable.

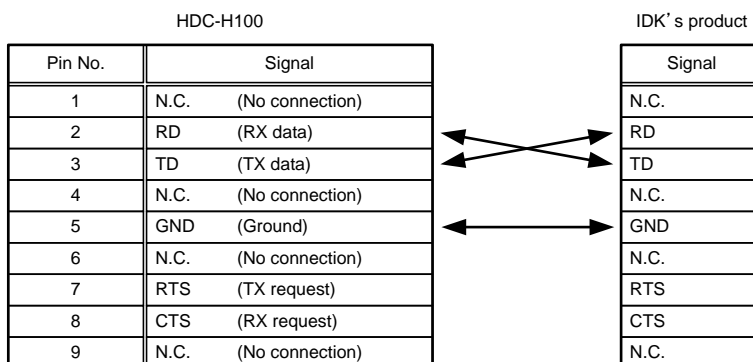

■ **Connecting to a product requiring straight connection:**

For RS-232C cable, make sure to use a straight cable.

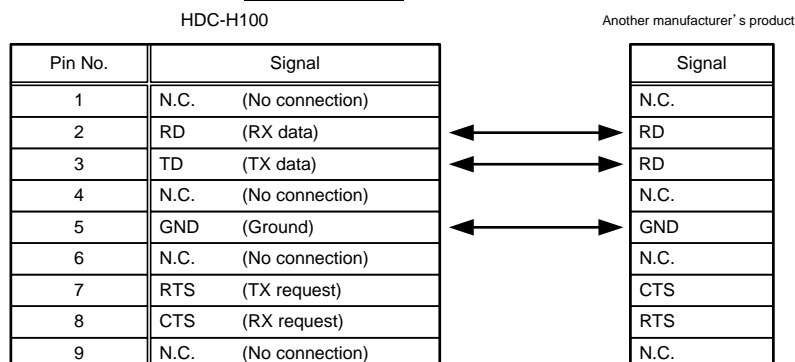

N.C. : No Connection

[Figure 6.3] RS-232C connector pin assignments

6.2 Product Specifications

■ Specifications

Item		Description	
Model number		HDC-TH100-C (Transmitter)	HDC-RH100-C (Receiver)
Input	Video	Number / Signal	1 input / HDMI (*1) - HDCP 1.4 / 2.2: Pass through (*2) - CEC: Pass through - TMDS clock: 25 MHz to 340 MHz
		Connector	1 female HDMI Type A (*3)
		Others	Color depth: 24 bit, 30 bit, 36 bit Deep Color (*4)
		Formats	480i/480p/576i/576p/720p/1080i/1080p/4K (*5) VGA to 4K (*5)
	Audio	Number / Signal	1 input / Multi-channel linear PCM up to 8 channels
		Connector	1 female HDMI Type A
Output	Video	Number / Signal	1 output / HDBaseT - HDCP 1.4 / 2.2: Pass through (*2) - CEC: Pass through - TMDS clock: 25 MHz to 340 MHz
		Connector	1 RJ-45
		Others	Color depth: 24 bit, 30 bit, 36 bit Deep Color (*4)
		Formats	480i/480p/576i/576p/720p/1080i/1080p/4K(*5) VGA to 4K (*5)
	Audio	Number / Signal	1 output / HDBaseT
		Connector	1 RJ-45
Plug & Play		Pass through	
Twisted pair cables		Cat6 UTP/STP cable, Cat5e UTP/STP cable (*6)	
Signal transmission distance (*7)		330ft (approx.) <100 m> (using a Cat6 UTP / STP cable) 4K format: 230ft (approx.) <70m> (Using a Cat6 UTP / STP cable)	
Control	Serial control port	Number / Signal	1 port / Full duplex Max. 115.2kbps
		Connector	1 male 9-pin D-Sub
	LAN control port	Number / Signal	1 port / 10Base-T (Auto Negotiation), 100Base-TX (Auto Negotiation), Auto MDI/MDI-X
		Connector	1 RJ-45
Others	AC adapter		Input: 100 - 240 VAC ± 10%, 50 Hz/60 Hz ± 3 Hz Output: 5VDC 2A 10Watt (AC adapter is supplied)
	Power consumption		Around 4 Watt
	Dimensions		4.17(W)×1.08(H)×3.94(D)" (approx.) <106(W)×27.5(H)×100(D)mm> (Quarter rack, not including projections)
	Weight		0.88 lbs. (approx.) <0.4kg>
	Temperature		Operating temperature: 32°F to 104°F<0°C to +40°C> Storage temperature: -4°F to +176°F<-20°C to +80°C>
	Humidity		Operating/ Storage humidity: 20 % to 90 % (Non Condensing)

*1 HEC and ARC are not supported.

*2 DVI signals protected by HDCP are not supported. Use our HDC-D100 twisted pair cable extender that supports DVI signals to transmit HDCP-compliant DVI signals.

- *3 Use an HDMI cable that is 2 m/6.56 feet or shorter.
- *4 For 4K format, 24 Hz/25 Hz/30 Hz/60 Hz (4:2:0) are supported.
- *5 For 4K format, only 24 bit is supported.
- *6 Straight connection of T568A or T568B. For over 50 m/164.04 feet, Cat6 cables are recommended.
- *7 The maximum extension distances of Cat6 UTP/STP cable and Cat5e UTP/STP cable depend on the shortest length of any cable being used to connect the transmitter, receiver, and sink device. The shortest cable length in that group is the controlling factor.

Notes:

- Specifications are subject to change without notice.
- All nominal levels are at $\pm 5\%$.
- The attached AC adapter is only for the HDC. Do not use it for other products.

7 Troubleshooting

In case this product does not operate smoothly, check the following items.

- Are this device and the connected devices turned on normally?
- Are cables connected correctly?
- Are there no loose connections?
- Are cables that are appropriate to this device being used?
- Are signal specifications of connected devices matched to each other?
- Are settings of the sink device correct?
- Are there any close objects that may cause noise?

If additional assistance is required, please perform the following tests and then contact us.

1. The problem occurs in all connectors?
 2. Connect the devices using genuine cables without connecting the HDC.
- The problem still cannot be solved? Please contact us for assistance.

User's guide of HDC-TH100-C/HDC-RH100-C

Ver. 1.0.0

Issued on: 11 June 2015



Headquarters

IDK Corporation
7-9-1 Chuo, Yamato-shi, Kanagawa-pref.
242-0021 JAPAN
TEL: +81-46-200-0764 FAX: +81-46-200-0765

Email: idx_eng@idx.co.jp URL: <http://www.idx.co.jp/en/index.html>



**Product information
Support**

Arvanics Corporation
3-8-3-3F Yamato Higashi, Yamato-shi, Kanagawa-pref.
242-0017 JAPAN
TEL: +81-46-259-6920 FAX: +81-46-259-6920

Email: info@arvanics.com URL: <http://www.arvanics.com>

Information in this document is subject to change without notice.
All rights reserved. All trademarks mentioned are the property of their respective owners.